

LT

EKSPLOATACINIŲ SAVYBIŲ DEKLARACIJA

pagal III priedą prie Reglamento (ES) Nr. 305/2011 (Statybos produktų reglamento)

 „Hilti“ daugiasluoksnių plokščių sraigčiai S-CD S, S-CDW S
 Nr. Hilti-SF-DoP-009

1. Unikalus produkto tipo identifikacinis kodas: „Hilti“ tvirtinimo varžtai daugiasluoksniams plokštėms S-CD S, S-CDW S

2. Tipo, partijos ar serijos numeris arba bet koks kitas elementas, pagal kurį galima identifikuoti statybos produktą, kaip reikalaujama pagal 11 straipsnio 4 dalį: tipas ir partijos numeris nurodyti ant pakuotės

3. Gamintojo numatyta statybos produkto naudojimo paskirtis ar paskirtys pagal taikomą darniąją techninę specifikaciją:

Bendrasis tipas ir paskirtis	Savaiminio gręžimo tvirtinimo varžtai, skirti daugiasluoksniams plokštėms
Taikomi produkto dydžiai	5,5 ir 6,5 skersmens varžtai
Pagrindo ir tvirtinimo medžiaga	Plienas pagal EN 10025-1 ir EN 10346 standartus, Mediena pagal EN 14081 standartą
Tvirtinimo detalės medžiaga	Nerūdijantis plienas (1.4301, 1.4401 arba 1.4571) pagal EN 10088 standartą
Apkrova	Statinė ir kvazistatinė apkrova (vėjo apkrova)

4. Gamintojo pavadinimas, registruotas komercinis pavadinimas arba registruotas prekės ženklas ir kontaktinis adresas, kaip reikalaujama pagal 11 straipsnio 5 dalį: „Hilti Aktiengesellschaft“, Tiesioginių tvirtinimo elementų padalinys, 9494 Šanas, Lichtenšteino kunigaikštystė

5. Kai taikoma, įgaliotojo atstovo, kuriam suteikti įgaliojimai apima 12 straipsnio 2 dalyje nurodytas užduotis, pavadinimas ir kontaktinis adresas: netaikoma.

6. Statybos produkto eksploatacinių savybių pastovumo vertinimo ir tikrinimo sistema (-os), kaip nustatyta V priede: 2+ sistema

7. Eksploatacinių savybių deklaracijos dėl statybos produkto, kuriam taikomas darnusis standartas, atveju: netaikoma.

8. Eksploatacinių savybių deklaracijos, susijusios su statybos produktu, kuriam buvo išduotas Europos techninis įvertinimas, atveju: „Deutsches Institut für Bautechnik“ (DIBt) išdavė ETA-13/0179 pagal EAD 330047-01-0602. Paskelbtoji įstaiga MPA-Karlsruhe 0769 atliko trečiosios šalies užduotis pagal 2+ sistemą ir išdavė gamyklinės gamybos kontrolės atitikties sertifikatą 0769-CPR-VAS-00705.

9. Deklaruojama (-os) eksploatacinė (-ės) savybė (-ės):

Esminė ypatybė	Eksploatacinės savybės	Darnioji techninė specifikacija
Būdingasis atsparumas tempimui $N_{R,k}$	1–16 priedai ETA-13/0179 (8-11, 16-27 priedai)	ETA 13/0179 EAD 330047-01-0602
Būdingasis atsparumas šlyties jėgoms $V_{R,k}$		
Didžiausia leistina varžto galvutės slinktis u		
Taikymo apribojimai	A1	
Reakcija į ugnį		

10. 1 ir 2 punktuose nurodytos produkto eksploatacinės savybės atitinka 9 punkte deklaruotas eksploatacines savybes. Už šios eksploatacinių savybių deklaracijos išleidimą atsakomybę prisiima tik 4 punkte nurodytas gamintojas.

Pasirašyta (gamintojo ir jo vardu):

Lars Taenzer
Tiesioginio tvirtinimo elementų padalinio vadovas

Pierre Hohmeier
Varžtinių tvirtinimo elementų kokybės vadovas

„Hilti Aktiengesellschaft“, Šanas, 2019-05-01

Annex 1:
ETA-13/0179, Annex 8

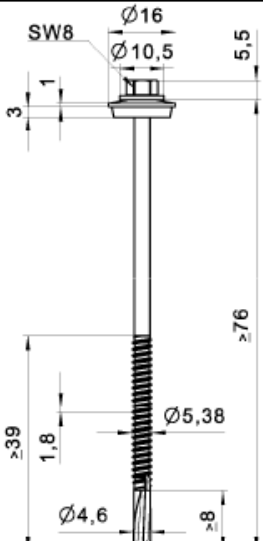

Material:
 Fastener: stainless Steel (1.4301, 1.4401, 1.4571) - EN 10088
 Washer: stainless Steel (1.4301) - EN 10088
 Component I: S280GD, S320GD, S350GD, S390GD, S420GD, S450GD - EN 10346
 Component II: S235, S275, S355, S420 - EN 10025-1, S280GD, S320GD, S350GD, S390GD, S420GD, S450GD - EN 10346

Drilling capacity: $\Sigma t_i \leq 6,00$ mm

Timber substructures:
no performance determined

t_{N1}, t_{N2}, d, D [mm]	t_i [mm]									
	1,50	2,00	2,50	3,00	4,00	5,00	6,00	8,00	≥ 10,0	
$V_{R,k}$ [kN]	0,40	0,65	0,65	0,65	0,65	0,65	0,65	—	—	—
	0,50	1,17	1,17	1,17	1,17	1,17	1,17	—	—	—
	0,55	1,36	1,36	1,36	1,36	1,36	1,36	—	—	—
	0,60	1,54	1,54	1,54	1,54	1,54	1,54	—	—	—
	0,63	1,65	1,65	1,65	1,65	1,65	1,65	—	—	—
	0,75	2,03	2,03	2,03	2,03	2,03	2,03	—	—	—
	0,88	2,40	2,40	2,40	2,40	2,40	2,40	—	—	—
	1,00	2,68	2,68	2,68	2,68	2,68	2,68	—	—	—
	$N_{R,k}$ [kN]	0,40	—	—	—	—	—	—	—	—
0,50		1,80	1,92	1,92	1,92	1,92	1,92	—	—	—
0,55		1,80	2,19	2,19	2,19	2,19	2,19	—	—	—
0,60		1,80	2,48	2,48	2,48	2,48	2,48	—	—	—
0,63		1,80	2,65	2,65	2,65	2,65	2,65	—	—	—
0,75		1,80	2,80	3,57	3,57	3,57	3,57	—	—	—
0,88		1,80	2,80	3,57	3,57	3,57	3,57	—	—	—
1,00		1,80	2,80	3,57	3,57	3,57	3,57	—	—	—
u [mm]		40	18,0	8,0	7,0	6,0	5,0	3,0	—	—
	50	22,0	10,5	9,0	7,5	6,5	4,3	—	—	—
	60	26,0	13,0	11,0	9,0	8,0	5,5	—	—	—
	70	29,5	16,5	14,0	12,0	11,5	6,8	—	—	—
	80	33,0	20,0	17,5	15,0	14,0	8,0	—	—	—
	100	33,0	20,0	17,5	15,0	14,0	10,0	—	—	—
	120	33,0	20,0	17,5	15,0	14,0	12,0	—	—	—
	≥ 140	33,0	20,0	17,5	15,0	14,0	14,0	—	—	—
$N_{R,k,II}$ [kN]	1,94	2,84	3,83	4,89	7,18	7,18	—	—	—	

If component t_{N1} resp. t_{N2} is made of steel grade higher than S280GD the grey highlighted values may be increased by 8,3%. If both components t_{N1} resp. t_{N2} and t_i are made of steel grade higher than S280GD all values $V_{R,k}$ and $N_{R,k}$ may be increased by 8,3%. If component t_i is made of steel grade higher than S235 or S280GD the values $N_{R,k,II}$ may be increased by 8,3%.

Self drilling screw	Annex 8
Hilti S-CDH 53 S 5,5 x L Hilti S-CDH 53 SS 5,5 x L with hexagon head and sealing washer Ø16 mm	

Annex 2:
ETA-13/0179, Annex 9

	<p>Material:</p> <p>Fastener: stainless Steel (1.4301, 1.4401, 1.4571) - EN 10088</p> <p>Washer: stainless Steel (1.4301) - EN 10088</p> <p>Component I: S280GD, S320GD, S350GD, S390GD, S420GD, S450GD - EN 10346</p> <p>Component II: S235, S275, S355, S420 - EN 10025-1 S280GD, S320GD, S350GD, S390GD, S420GD, S450GD - EN 10346</p>
	<p>Drilling capacity: $\Sigma t_i \leq 6,00$ mm</p>
	<p>Timber substructures: no performance determined</p>

t_{N1}, t_{N2}, d, D [mm]	t_{II} [mm]									
	1,50	2,00	2,50	3,00	4,00	5,00	6,00	8,00	≥ 10,0	
$V_{R,k}$ [kN]	0,40	0,65	0,65	0,65	0,65	0,65	0,65	—	—	—
	0,50	1,17	1,17	1,17	1,17	1,17	1,17	—	—	—
	0,55	1,36	1,36	1,36	1,36	1,36	1,36	—	—	—
	0,60	1,54	1,54	1,54	1,54	1,54	1,54	—	—	—
	0,63	1,65	1,65	1,65	1,65	1,65	1,65	—	—	—
	0,75	2,03	2,03	2,03	2,03	2,03	2,03	—	—	—
	0,88	2,40	2,40	2,40	2,40	2,40	2,40	—	—	—
	1,00	2,68	2,68	2,68	2,68	2,68	2,68	—	—	—
	$N_{R,k}$ [kN]	0,40	—	—	—	—	—	—	—	—
0,50		1,80	2,60	2,60	2,60	2,60	2,60	—	—	—
0,55		1,80	2,80	3,00	3,00	3,00	3,00	—	—	—
0,60		1,80	2,80	3,25	3,25	3,25	3,25	—	—	—
0,63		1,80	2,80	3,40	3,40	3,40	3,40	—	—	—
0,75		1,80	2,80	3,80	4,20	4,20	4,20	—	—	—
0,88		1,80	2,80	3,80	4,50	4,50	4,50	—	—	—
1,00		1,80	2,80	3,80	4,50	4,50	4,50	—	—	—
u [mm]		40	18,0	8,0	7,0	6,0	5,0	3,0	—	—
	50	22,0	10,5	9,0	7,5	6,5	4,3	—	—	—
	60	26,0	13,0	11,0	9,0	8,0	5,5	—	—	—
	70	29,5	16,5	14,0	12,0	11,5	6,8	—	—	—
	80	33,0	20,0	17,5	15,0	14,0	8,0	—	—	—
	100	33,0	20,0	17,5	15,0	14,0	10,0	—	—	—
	120	33,0	20,0	17,5	15,0	14,0	12,0	—	—	—
	≥ 140	33,0	20,0	17,5	15,0	14,0	14,0	—	—	—
$N_{R,k,II}$ [kN]	1,94	2,84	3,83	4,89	7,18	7,18	—	—	—	

If component t_{N1} resp. t_{N2} is made of steel grade higher than S280GD the grey highlighted values may be increased by 8,3%. If both components t_{N1} resp. t_{N2} and t_{II} are made of steel grade higher than S280GD all values $V_{R,k}$ and $N_{R,k}$ may be increased by 8,3%. If component t_{II} is made of steel grade higher than S235 or S280GD the values $N_{R,k,II}$ may be increased by 8,3%.

Self drilling screw	Annex 9
Hilti S-CDH 63 S 5,5 x L Hilti S-CDH 63 SS 5,5 x L Hilti S-CDH 73 S 5,5 x L Hilti S-CDH 73 SS 5,5 x L with hexagon head and sealing washer $\geq \text{Ø}19$ mm	

Annex 3:
ETA-13/0179, Annex 10

	Material: Fastener: stainless Steel (1.4301, 1.4401, 1.4571) - EN 10088 Washer: stainless Steel (1.4301) - EN 10088 Component I: S280GD, S320GD, S350GD, S390GD, S420GD, S450GD - EN 10346 Component II: S235, S275, S355, S420 - EN 10025-1, S280GD, S320GD, S350GD, S390GD, S420GD, S450GD - EN 10346
	Drilling capacity: $\Sigma t_i \leq 6,00$ mm
Timber substructures: no performance determined	

t_{N1}, t_{N2}, d, D [mm]	t_{II} [mm]									
	1,50	2,00	2,50	3,00	4,00	5,00	6,00	8,00	≥ 10,0	
$V_{R,k}$ [kN]	0,40	0,65	0,65	0,65	0,65	0,65	0,65	—	—	—
	0,50	1,17	1,17	1,17	1,17	1,17	1,17	—	—	—
	0,55	1,36	1,36	1,36	1,36	1,36	1,36	—	—	—
	0,60	1,54	1,54	1,54	1,54	1,54	1,54	—	—	—
	0,63	1,65	1,65	1,65	1,65	1,65	1,65	—	—	—
	0,75	2,03	2,03	2,03	2,03	2,03	2,03	—	—	—
	0,88	2,40	2,40	2,40	2,40	2,40	2,40	—	—	—
	1,00	2,68	2,68	2,68	2,68	2,68	2,68	—	—	—
$N_{R,k}$ [kN]	0,40	—	—	—	—	—	—	—	—	—
	0,50	1,80	1,92	1,92	1,92	1,92	1,92	—	—	—
	0,55	1,80	2,19	2,19	2,19	2,19	2,19	—	—	—
	0,60	1,80	2,48	2,48	2,48	2,48	2,48	—	—	—
	0,63	1,80	2,65	2,65	2,65	2,65	2,65	—	—	—
	0,75	1,80	2,80	3,57	3,57	3,57	3,57	—	—	—
	0,88	1,80	2,80	3,57	3,57	3,57	3,57	—	—	—
	1,00	1,80	2,80	3,57	3,57	3,57	3,57	—	—	—
u [mm]	40	18,0	8,0	7,0	6,0	5,0	3,0	—	—	—
	50	22,0	10,5	9,0	7,5	6,5	4,3	—	—	—
	60	26,0	13,0	11,0	9,0	8,0	5,5	—	—	—
	70	29,5	16,5	14,0	12,0	11,5	6,8	—	—	—
	80	33,0	20,0	17,5	15,0	14,0	8,0	—	—	—
	100	33,0	20,0	17,5	15,0	14,0	10,0	—	—	—
	120	33,0	20,0	17,5	15,0	14,0	12,0	—	—	—
≥ 140	33,0	20,0	17,5	15,0	14,0	14,0	—	—	—	
$N_{R,k,II}$ [kN]	1,94	2,84	3,83	4,89	7,18	7,18	—	—	—	

If component t_{N1} resp. t_{N2} is made of steel grade higher than S280GD the grey highlighted values may be increased by 8,3%. If both components t_{N1} resp. t_{N2} and t_{II} are made of steel grade higher than S280GD all values $V_{R,k}$ and $N_{R,k}$ may be increased by 8,3%. If component t_{II} is made of steel grade higher than S235 or S280GD the values $N_{R,k,II}$ may be increased by 8,3%.

Self drilling screw	Annex 10
Hilti S-CD 53 S 5,5 x L Hilti S-CD 53 SS 5,5 x L with hexagon head and sealing washer Ø16 mm	

Annex 4:
ETA-13/0179, Annex 11

Material:
Fastener: stainless Steel (1.4301, 1.4401, 1.4571) - EN 10088
Washer: stainless Steel (1.4301) - EN 10088
Component I: S280GD, S320GD, S350GD, S390GD, S420GD, S450GD - EN 10346
Component II: S235, S275, S355, S420 - EN 10025-1, S280GD, S320GD, S350GD, S390GD, S420GD, S450GD - EN 10346

Drilling capacity: $\Sigma t_i \leq 6,00$ mm

Timber substructures:
no performance determined

t_{N1}, t_{N2}, d, D [mm]	t_i [mm]									
	1,50	2,00	2,50	3,00	4,00	5,00	6,00	8,00	$\geq 10,0$	
$V_{R,k}$ [kN]	0,40	0,65	0,65	0,65	0,65	0,65	0,65	—	—	—
	0,50	1,17	1,17	1,17	1,17	1,17	1,17	—	—	—
	0,55	1,36	1,36	1,36	1,36	1,36	1,36	—	—	—
	0,60	1,54	1,54	1,54	1,54	1,54	1,54	—	—	—
	0,63	1,65	1,65	1,65	1,65	1,65	1,65	—	—	—
	0,75	2,03	2,03	2,03	2,03	2,03	2,03	—	—	—
	0,88	2,40	2,40	2,40	2,40	2,40	2,40	—	—	—
	1,00	2,68	2,68	2,68	2,68	2,68	2,68	—	—	—
$N_{R,k}$ [kN]	0,40	—	—	—	—	—	—	—	—	—
	0,50	1,80	2,60	2,60	2,60	2,60	2,60	—	—	—
	0,55	1,80	2,80	3,00	3,00	3,00	3,00	—	—	—
	0,60	1,80	2,80	3,25	3,25	3,25	3,25	—	—	—
	0,63	1,80	2,80	3,40	3,40	3,40	3,40	—	—	—
	0,75	1,80	2,80	3,80	4,20	4,20	4,20	—	—	—
	0,88	1,80	2,80	3,80	4,50	4,50	4,50	—	—	—
	1,00	1,80	2,80	3,80	4,50	4,50	4,50	—	—	—
u [mm]	40	18,0	8,0	7,0	6,0	5,0	3,0	—	—	—
	50	22,0	10,5	9,0	7,5	6,5	4,3	—	—	—
	60	26,0	13,0	11,0	9,0	8,0	5,5	—	—	—
	70	29,5	16,5	14,0	12,0	11,5	6,8	—	—	—
	80	33,0	20,0	17,5	15,0	14,0	8,0	—	—	—
	100	33,0	20,0	17,5	15,0	14,0	10,0	—	—	—
	120	33,0	20,0	17,5	15,0	14,0	12,0	—	—	—
	≥ 140	33,0	20,0	17,5	15,0	14,0	14,0	—	—	—
$N_{R,k,II}$ [kN]	1,94	2,84	3,83	4,89	7,18	7,18	—	—	—	

If component t_{N1} resp. t_{N2} is made of steel grade higher than S280GD the grey highlighted values may be increased by 8,3%. If both components t_{N1} resp. t_{N2} and t_i are made of steel grade higher than S280GD all values $V_{R,k}$ and $N_{R,k}$ may be increased by 8,3%. If component t_i is made of steel grade higher than S235 or S280GD the values $N_{R,k,II}$ may be increased by 8,3%.

Self drilling screw	Annex 11
Hilti S-CD 63 S 5,5 x L Hilti S-CD 63 SS 5,5 x L Hilti S-CD 73 S 5,5 x L Hilti S-CD 73 SS 5,5 x L with hexagon head and sealing washer $\geq \varnothing 19$ mm	

Annex 5:
ETA-13/0179, Annex 16

Material:
 Fastener: stainless Steel (1.4301, 1.4401, 1.4571) - EN 10088
 Washer: stainless Steel (1.4301) - EN 10088
 Component I: S280GD, S320GD, S350GD - EN 10346
 Component II: S235 - EN 10025-1
 S280GD, S320GD - EN 10346

Drilling capacity: $\Sigma t_i \leq 12,00$ mm

Timber substructures:
no performance determined

t_{N1}, t_{N2}, d, D [mm]	t_{II} [mm]									
	3,00	4,00	5,00	6,00	8,00	9,00	10,0	11,0	$\geq 12,0$	
$V_{R,k}$ [kN]	0,40	0,99	0,99	0,99	0,99	0,99	0,99	0,99	0,99	—
	0,50	1,46	1,46	1,46	1,46	1,46	1,46	1,46	1,46	—
	0,55	1,62	1,62	1,62	1,62	1,62	1,62	1,62	1,62	—
	0,60	1,80	1,80	1,80	1,80	1,80	1,80	1,80	1,80	—
	0,63	1,90	1,90	1,90	1,90	1,90	1,90	1,90	1,90	—
	0,75	2,37	2,37	2,37	2,37	2,37	2,37	2,37	2,37	—
	0,88	2,94	2,94	2,94	2,94	2,94	2,94	2,94	2,94	—
	1,00	3,52	3,52	3,52	3,52	3,52	3,52	3,52	3,52	—
$N_{R,k}$ [kN]	0,40	—	—	—	—	—	—	—	—	—
	0,50	1,96	1,96	1,96	1,96	1,96	1,96	1,96	1,96	—
	0,55	2,25	2,25	2,25	2,25	2,25	2,25	2,25	2,25	—
	0,60	2,57	2,57	2,57	2,57	2,57	2,57	2,57	2,57	—
	0,63	2,76	2,76	2,76	2,76	2,76	2,76	2,76	2,76	—
	0,75	3,49	3,49	3,49	3,49	3,49	3,49	3,49	3,49	—
	0,88	3,49	3,49	3,49	3,49	3,49	3,49	3,49	3,49	—
	1,00	3,49	3,49	3,49	3,49	3,49	3,49	3,49	3,49	—
u [mm]	40	6,0	5,5	5,0	4,0	4,0	4,0	4,0	4,0	—
	50	8,0	7,5	7,0	6,0	6,0	6,0	6,0	6,0	—
	60	10,0	9,5	9,0	8,0	8,0	8,0	8,0	8,0	—
	70	12,5	11,5	11,0	9,5	9,5	9,5	9,5	9,5	—
	80	15,0	14,0	13,0	11,0	11,0	11,0	11,0	11,0	—
	100	15,0	14,0	13,0	11,0	11,0	11,0	11,0	11,0	—
	120	15,0	14,0	13,0	11,0	11,0	11,0	11,0	11,0	—
≥ 140	15,0	14,0	13,0	11,0	11,0	11,0	11,0	11,0	—	
$N_{R,k,II}$ [kN]	4,65	6,40	7,74	8,36	8,36	8,36	8,36	8,36	—	

If component t_{N1} resp. t_{N2} is made of S320GD or S350GD the grey highlighted values may be increased by 8,3%.
 If component t_{II} is made of S320GD the values $N_{R,k,II}$ may be increased by 8,3%.

Self drilling screw	Annex 16
Hilti S-CDH 55 S 5,5 x L Hilti S-CDH 55 SS 5,5 x L with hexagon head and sealing washer $\varnothing 16$ mm	

Annex 6:
ETA-13/0179, Annex 17

Material:
 Fastener: stainless Steel (1.4301, 1.4401, 1.4571) - EN 10088
 Washer: stainless Steel (1.4301) - EN 10088
 Component I: S280GD, S320GD, S350GD - EN 10346
 Component II: S235 - EN 10025-1
 S280GD, S320GD - EN 10346

Drilling capacity: $\Sigma t_i \leq 12,00$ mm

Timber substructures:
no performance determined

t_{N1}, t_{N2}, d, D [mm]	t_i [mm]									
	3,00	4,00	5,00	6,00	8,00	9,00	10,0	11,0	$\geq 12,0$	
$V_{R,k}$ [kN]	0,40	0,99	0,99	0,99	0,99	0,99	0,99	0,99	0,99	—
	0,50	1,46	1,46	1,46	1,46	1,46	1,46	1,46	1,46	—
	0,55	1,62	1,62	1,62	1,62	1,62	1,62	1,62	1,62	—
	0,60	1,80	1,80	1,80	1,80	1,80	1,80	1,80	1,80	—
	0,63	1,90	1,90	1,90	1,90	1,90	1,90	1,90	1,90	—
	0,75	2,37	2,37	2,37	2,37	2,37	2,37	2,37	2,37	—
	0,88	2,94	2,94	2,94	2,94	2,94	2,94	2,94	2,94	—
	1,00	3,52	3,52	3,52	3,52	3,52	3,52	3,52	3,52	—
	$N_{R,k}$ [kN]	0,40	—	—	—	—	—	—	—	—
0,50		2,10	2,10	2,10	2,10	2,10	2,10	2,10	2,10	—
0,55		2,50	2,50	2,50	2,50	2,50	2,50	2,50	2,50	—
0,60		2,75	2,75	2,75	2,75	2,75	2,75	2,75	2,75	—
0,63		2,90	2,90	2,90	2,90	2,90	2,90	2,90	2,90	—
0,75		3,70	3,70	3,70	3,70	3,70	3,70	3,70	3,70	—
0,88		4,50	4,60	4,60	4,60	4,60	4,60	4,60	4,60	—
1,00		4,50	5,20	5,20	5,20	5,20	5,20	5,20	5,20	—
u [mm]		40	6,0	5,5	5,0	4,0	4,0	4,0	4,0	4,0
	50	8,0	7,5	7,0	6,0	6,0	6,0	6,0	6,0	—
	60	10,0	9,5	9,0	8,0	8,0	8,0	8,0	8,0	—
	70	12,5	11,5	11,0	9,5	9,5	9,5	9,5	9,5	—
	80	15,0	14,0	13,0	11,0	11,0	11,0	11,0	11,0	—
	100	15,0	14,0	13,0	11,0	11,0	11,0	11,0	11,0	—
	120	15,0	14,0	13,0	11,0	11,0	11,0	11,0	11,0	—
≥ 140	15,0	14,0	13,0	11,0	11,0	11,0	11,0	11,0	—	
$N_{R,k,II}$ [kN]	4,65	6,40	7,74	8,36	8,36	8,36	8,36	8,36	—	

If component t_{N1} resp. t_{N2} is made of S320GD or S350GD the grey highlighted values may be increased by 8,3%. If both components t_{N1} and t_i are made of S320GD or S350GD the values $N_{R,k}$ may be increased by 8,3%.
 If component t_i is made of S320GD the values $N_{R,k,II}$ may be increased by 8,3%.

Self drilling screw	Annex 17
Hilti S-CDH 65 S 5,5 x L Hilti S-CDH 65 SS 5,5 x L Hilti S-CDH 75 S 5,5 x L Hilti S-CDH 75 SS 5,5 x L with hexagon head and sealing washer $\geq \varnothing 19$ mm	

Annex 7:
ETA-13/0179, Annex 18

Material:
 Fastener: stainless Steel (1.4301, 1.4401, 1.4571) - EN 10088
 Washer: stainless Steel (1.4301) - EN 10088
 Component I: S280GD, S320GD, S350GD - EN 10346
 Component II: S235 - EN 10025-1
 S280GD, S320GD - EN 10346

Drilling capacity: $\Sigma t_i \leq 12,00$ mm

Timber substructures:
no performance determined

t_{N1}, t_{N2}, d, D [mm]	t_i [mm]									
	3,00	4,00	5,00	6,00	8,00	9,00	10,0	11,0	$\geq 12,0$	
$V_{R,k}$ [kN]	0,40	0,99	0,99	0,99	0,99	0,99	0,99	0,99	0,99	—
	0,50	1,46	1,46	1,46	1,46	1,46	1,46	1,46	1,46	—
	0,55	1,62	1,62	1,62	1,62	1,62	1,62	1,62	1,62	—
	0,60	1,80	1,80	1,80	1,80	1,80	1,80	1,80	1,80	—
	0,63	1,90	1,90	1,90	1,90	1,90	1,90	1,90	1,90	—
	0,75	2,37	2,37	2,37	2,37	2,37	2,37	2,37	2,37	—
	0,88	2,94	2,94	2,94	2,94	2,94	2,94	2,94	2,94	—
	1,00	3,52	3,52	3,52	3,52	3,52	3,52	3,52	3,52	—
$N_{R,k}$ [kN]	0,40	—	—	—	—	—	—	—	—	—
	0,50	1,96	1,96	1,96	1,96	1,96	1,96	1,96	1,96	—
	0,55	2,25	2,25	2,25	2,25	2,25	2,25	2,25	2,25	—
	0,60	2,57	2,57	2,57	2,57	2,57	2,57	2,57	2,57	—
	0,63	2,76	2,76	2,76	2,76	2,76	2,76	2,76	2,76	—
	0,75	3,49	3,49	3,49	3,49	3,49	3,49	3,49	3,49	—
	0,88	3,49	3,49	3,49	3,49	3,49	3,49	3,49	3,49	—
	1,00	3,49	3,49	3,49	3,49	3,49	3,49	3,49	3,49	—
u [mm]	40	6,0	5,5	5,0	4,0	4,0	4,0	4,0	4,0	—
	50	8,0	7,5	7,0	6,0	6,0	6,0	6,0	6,0	—
	60	10,0	9,5	9,0	8,0	8,0	8,0	8,0	8,0	—
	70	12,5	11,5	11,0	9,5	9,5	9,5	9,5	9,5	—
	80	15,0	14,0	13,0	11,0	11,0	11,0	11,0	11,0	—
	100	15,0	14,0	13,0	11,0	11,0	11,0	11,0	11,0	—
	120	15,0	14,0	13,0	11,0	11,0	11,0	11,0	11,0	—
≥ 140	15,0	14,0	13,0	11,0	11,0	11,0	11,0	11,0	—	
$N_{R,k,II}$ [kN]	4,65	6,40	7,74	8,36	8,36	8,36	8,36	8,36	—	

If component t_{N1} resp. t_{N2} is made of S320GD or S350GD the grey highlighted values may be increased by 8,3%.
 If component t_i is made of S320GD the values $N_{R,k,II}$ may be increased by 8,3%.

Self drilling screw	Annex 18
Hilti S-CD 55 S 5,5 x L Hilti S-CD 55 SS 5,5 x L with hexagon head and sealing washer $\varnothing 16$ mm	

Annex 8:
ETA-13/0179, Annex 19

Material:
 Fastener: stainless Steel (1.4301, 1.4401, 1.4571) - EN 10088
 Washer: stainless Steel (1.4301) - EN 10088
 Component I: S280GD, S320GD, S350GD - EN 10346
 Component II: S235 - EN 10025-1
 S280GD, S320GD - EN 10346

Drilling capacity: $\Sigma t_i \leq 12,00$ mm

Timber substructures:
no performance determined

t_{N1}, t_{N2}, d, D [mm]	t_{II} [mm]									
	3,00	4,00	5,00	6,00	8,00	9,00	10,0	11,0	$\geq 12,0$	
$V_{R,k}$ [kN]	0,40	0,99	0,99	0,99	0,99	0,99	0,99	0,99	0,99	—
	0,50	1,46	1,46	1,46	1,46	1,46	1,46	1,46	1,46	—
	0,55	1,62	1,62	1,62	1,62	1,62	1,62	1,62	1,62	—
	0,60	1,80	1,80	1,80	1,80	1,80	1,80	1,80	1,80	—
	0,63	1,90	1,90	1,90	1,90	1,90	1,90	1,90	1,90	—
	0,75	2,37	2,37	2,37	2,37	2,37	2,37	2,37	2,37	—
	0,88	2,94	2,94	2,94	2,94	2,94	2,94	2,94	2,94	—
	1,00	3,52	3,52	3,52	3,52	3,52	3,52	3,52	3,52	—
$N_{R,k}$ [kN]	0,40	—	—	—	—	—	—	—	—	—
	0,50	2,10	2,10	2,10	2,10	2,10	2,10	2,10	2,10	—
	0,55	2,50	2,50	2,50	2,50	2,50	2,50	2,50	2,50	—
	0,60	2,75	2,75	2,75	2,75	2,75	2,75	2,75	2,75	—
	0,63	2,90	2,90	2,90	2,90	2,90	2,90	2,90	2,90	—
	0,75	3,70	3,70	3,70	3,70	3,70	3,70	3,70	3,70	—
	0,88	4,50	4,60	4,60	4,60	4,60	4,60	4,60	4,60	—
	1,00	4,50	5,20	5,20	5,20	5,20	5,20	5,20	5,20	—
u [mm]	40	6,0	5,5	5,0	4,0	4,0	4,0	4,0	4,0	—
	50	8,0	7,5	7,0	6,0	6,0	6,0	6,0	6,0	—
	60	10,0	9,5	9,0	8,0	8,0	8,0	8,0	8,0	—
	70	12,5	11,5	11,0	9,5	9,5	9,5	9,5	9,5	—
	80	15,0	14,0	13,0	11,0	11,0	11,0	11,0	11,0	—
	100	15,0	14,0	13,0	11,0	11,0	11,0	11,0	11,0	—
	120	15,0	14,0	13,0	11,0	11,0	11,0	11,0	11,0	—
≥ 140	15,0	14,0	13,0	11,0	11,0	11,0	11,0	11,0	—	
$N_{R,k,II}$ [kN]	4,65	6,40	7,74	8,36	8,36	8,36	8,36	8,36	—	

If component t_{N1} resp. t_{N2} is made of S320GD or S350GD the grey highlighted values may be increased by 8,3%. If both components t_{N1} and t_{II} are made of S320GD or S350GD the values $N_{R,k}$ may be increased by 8,3%.
 If component t_{II} is made of S320GD the values $N_{R,k,II}$ may be increased by 8,3%.

Self drilling screw	Annex 19
Hilti S-CD 65 S 5,5 x L Hilti S-CD 65 SS 5,5 x L Hilti S-CD 75 S 5,5 x L Hilti S-CD 75 SS 5,5 x L with hexagon head and sealing washer $\geq \varnothing 19$ mm	

Annex 9:
ETA-13/0179, Annex 20

Material:
 Fastener: stainless Steel (1.4301, 1.4401, 1.4571) - EN 10088
 Washer: stainless Steel (1.4301) - EN 10088
 Component I: S280GD, S320GD, S350GD - EN 10346
 Component II: S235, S275, S355 - EN 10025-1
 S280GD, S320GD, S350GD - EN 10346

Drilling capacity: $\Sigma t_i \leq 15,00$ mm

Timber substructures:
no performance determined

t_{N1}, t_{N2}, d, D [mm]	t_{II} [mm]										
	4,00	5,00	6,00	7,00	8,00	$\geq 10,0$	—	—	—	—	
$V_{R,k}$ [kN]	0,40	0,82	0,82	0,82	0,82	0,82	0,82	—	—	—	—
	0,50	0,93	0,93	0,93	0,93	0,93	0,93	—	—	—	—
	0,55	1,12	1,12	1,12	1,12	1,12	1,12	—	—	—	—
	0,60	1,31	1,31	1,31	1,31	1,31	1,31	—	—	—	—
	0,63	1,42	1,42	1,42	1,42	1,42	1,42	—	—	—	—
	0,75	1,88	1,88	1,88	1,88	1,88	1,88	—	—	—	—
	0,88	2,33	2,33	2,33	2,33	2,33	2,33	—	—	—	—
	1,00	2,74	2,74	2,74	2,74	2,74	2,74	—	—	—	—
$N_{R,k}$ [kN]	0,40	1,46	1,46	1,46	1,46	1,46	1,46	—	—	—	—
	0,50	1,89	1,89	1,89	1,89	1,89	1,89	—	—	—	—
	0,55	2,21	2,21	2,21	2,21	2,21	2,21	—	—	—	—
	0,60	2,53	2,53	2,53	2,53	2,53	2,53	—	—	—	—
	0,63	2,73	2,73	2,73	2,73	2,73	2,73	—	—	—	—
	0,75	3,50	3,50	3,50	3,50	3,50	3,50	—	—	—	—
	0,88	3,68	3,68	3,68	3,68	3,68	3,68	—	—	—	—
	1,00	3,84	3,84	3,84	3,84	3,84	3,84	—	—	—	—
u [mm]	40	3,0	3,0	3,0	3,0	3,0	3,0	—	—	—	—
	50	4,5	4,5	4,5	4,5	4,5	4,5	—	—	—	—
	60	6,0	6,0	6,0	6,0	6,0	6,0	—	—	—	—
	70	7,4	7,4	7,4	7,4	7,4	7,4	—	—	—	—
	80	8,8	8,8	8,8	8,8	8,8	8,8	—	—	—	—
	90	10,1	10,1	10,1	10,1	10,1	10,1	—	—	—	—
≥ 100	11,5	11,5	11,5	11,5	11,5	11,5	—	—	—	—	
$N_{R,k,II}$ [kN]	3,92	4,92	5,91	6,22	6,52	6,52	—	—	—	—	

No additional regulations.

Self drilling screw	Annex 20
Hilti S-CDH 55 GS 5,5 x L Hilti S-CDH 55 GSS 5,5 x L with hexagon head and sealing washer Ø16 mm	

Annex 10:
ETA-13/0179, Annex 21

	<p>Material: Fastener: stainless Steel (1.4301, 1.4401, 1.4571) - EN 10088 Washer: stainless Steel (1.4301) - EN 10088 Component I: S280GD, S320GD, S350GD - EN 10346 Component II: S235, S275, S355 - EN 10025-1 S280GD, S320GD, S350GD - EN 10346</p>																																																																																																																																																																																																																																																																								
<p>Drilling capacity: $\Sigma t_i \leq 15,00$ mm</p>																																																																																																																																																																																																																																																																									
<p>Timber substructures: no performance determined</p>																																																																																																																																																																																																																																																																									
<table border="1"> <thead> <tr> <th rowspan="2"></th> <th rowspan="2">t_{N1}, t_{N2}, d, D [mm]</th> <th colspan="9">t_{II} [mm]</th> </tr> <tr> <th>4,00</th> <th>5,00</th> <th>6,00</th> <th>7,00</th> <th>8,00</th> <th>$\geq 10,0$</th> <th>—</th> <th>—</th> <th>—</th> </tr> </thead> <tbody> <tr> <td rowspan="8">$V_{R,k}$ [kN]</td> <td>0,40</td> <td>0,82</td> <td>0,82</td> <td>0,82</td> <td>0,82</td> <td>0,82</td> <td>0,82</td> <td>—</td> <td>—</td> <td>—</td> </tr> <tr> <td>0,50</td> <td>0,93</td> <td>1,12</td> <td>1,30</td> <td>1,30</td> <td>1,30</td> <td>1,30</td> <td>—</td> <td>—</td> <td>—</td> </tr> <tr> <td>0,55</td> <td>1,12</td> <td>1,28</td> <td>1,44</td> <td>1,44</td> <td>1,44</td> <td>1,44</td> <td>—</td> <td>—</td> <td>—</td> </tr> <tr> <td>0,60</td> <td>1,31</td> <td>1,45</td> <td>1,58</td> <td>1,58</td> <td>1,58</td> <td>1,58</td> <td>—</td> <td>—</td> <td>—</td> </tr> <tr> <td>0,63</td> <td>1,42</td> <td>1,54</td> <td>1,66</td> <td>1,66</td> <td>1,66</td> <td>1,66</td> <td>—</td> <td>—</td> <td>—</td> </tr> <tr> <td>0,75</td> <td>1,88</td> <td>1,94</td> <td>2,00</td> <td>2,00</td> <td>2,00</td> <td>2,00</td> <td>—</td> <td>—</td> <td>—</td> </tr> <tr> <td>0,88</td> <td>2,33</td> <td>2,57</td> <td>2,81</td> <td>2,81</td> <td>2,81</td> <td>2,81</td> <td>—</td> <td>—</td> <td>—</td> </tr> <tr> <td>1,00</td> <td>2,74</td> <td>3,15</td> <td>3,56</td> <td>3,56</td> <td>3,56</td> <td>3,56</td> <td>—</td> <td>—</td> <td>—</td> </tr> <tr> <td rowspan="8">$N_{R,k}$ [kN]</td> <td>0,40</td> <td>1,46</td> <td>1,46</td> <td>1,46</td> <td>1,46</td> <td>1,46</td> <td>1,46</td> <td>—</td> <td>—</td> <td>—</td> </tr> <tr> <td>0,50</td> <td>1,89</td> <td>1,89</td> <td>1,89</td> <td>1,89</td> <td>1,89</td> <td>1,89</td> <td>—</td> <td>—</td> <td>—</td> </tr> <tr> <td>0,55</td> <td>2,21</td> <td>2,21</td> <td>2,21</td> <td>2,21</td> <td>2,21</td> <td>2,21</td> <td>—</td> <td>—</td> <td>—</td> </tr> <tr> <td>0,60</td> <td>2,53</td> <td>2,53</td> <td>2,53</td> <td>2,53</td> <td>2,53</td> <td>2,53</td> <td>—</td> <td>—</td> <td>—</td> </tr> <tr> <td>0,63</td> <td>2,73</td> <td>2,73</td> <td>2,73</td> <td>2,73</td> <td>2,73</td> <td>2,73</td> <td>—</td> <td>—</td> <td>—</td> </tr> <tr> <td>0,75</td> <td>3,50</td> <td>3,50</td> <td>3,50</td> <td>3,50</td> <td>3,50</td> <td>3,50</td> <td>—</td> <td>—</td> <td>—</td> </tr> <tr> <td>0,88</td> <td>3,68</td> <td>3,68</td> <td>3,68</td> <td>3,68</td> <td>3,68</td> <td>3,68</td> <td>—</td> <td>—</td> <td>—</td> </tr> <tr> <td>1,00</td> <td>3,84</td> <td>3,84</td> <td>3,84</td> <td>3,84</td> <td>3,84</td> <td>3,84</td> <td>—</td> <td>—</td> <td>—</td> </tr> <tr> <td rowspan="6">u [mm]</td> <td>40</td> <td>3,0</td> <td>3,0</td> <td>3,0</td> <td>3,0</td> <td>3,0</td> <td>3,0</td> <td>—</td> <td>—</td> <td>—</td> </tr> <tr> <td>50</td> <td>4,5</td> <td>4,5</td> <td>4,5</td> <td>4,5</td> <td>4,5</td> <td>4,5</td> <td>—</td> <td>—</td> <td>—</td> </tr> <tr> <td>60</td> <td>6,0</td> <td>6,0</td> <td>6,0</td> <td>6,0</td> <td>6,0</td> <td>6,0</td> <td>—</td> <td>—</td> <td>—</td> </tr> <tr> <td>70</td> <td>7,4</td> <td>7,4</td> <td>7,4</td> <td>7,4</td> <td>7,4</td> <td>7,4</td> <td>—</td> <td>—</td> <td>—</td> </tr> <tr> <td>80</td> <td>8,8</td> <td>8,8</td> <td>8,8</td> <td>8,8</td> <td>8,8</td> <td>8,8</td> <td>—</td> <td>—</td> <td>—</td> </tr> <tr> <td>90</td> <td>10,1</td> <td>10,1</td> <td>10,1</td> <td>10,1</td> <td>10,1</td> <td>10,1</td> <td>—</td> <td>—</td> <td>—</td> </tr> <tr> <td>≥ 100</td> <td>11,5</td> <td>11,5</td> <td>11,5</td> <td>11,5</td> <td>11,5</td> <td>11,5</td> <td>—</td> <td>—</td> <td>—</td> </tr> <tr> <td>$N_{R,k,II}$ [kN]</td> <td></td> <td>3,92</td> <td>4,92</td> <td>5,91</td> <td>6,22</td> <td>6,52</td> <td>6,52</td> <td>—</td> <td>—</td> <td>—</td> </tr> </tbody> </table>		t_{N1}, t_{N2}, d, D [mm]	t_{II} [mm]									4,00	5,00	6,00	7,00	8,00	$\geq 10,0$	—	—	—	$V_{R,k}$ [kN]	0,40	0,82	0,82	0,82	0,82	0,82	0,82	—	—	—	0,50	0,93	1,12	1,30	1,30	1,30	1,30	—	—	—	0,55	1,12	1,28	1,44	1,44	1,44	1,44	—	—	—	0,60	1,31	1,45	1,58	1,58	1,58	1,58	—	—	—	0,63	1,42	1,54	1,66	1,66	1,66	1,66	—	—	—	0,75	1,88	1,94	2,00	2,00	2,00	2,00	—	—	—	0,88	2,33	2,57	2,81	2,81	2,81	2,81	—	—	—	1,00	2,74	3,15	3,56	3,56	3,56	3,56	—	—	—	$N_{R,k}$ [kN]	0,40	1,46	1,46	1,46	1,46	1,46	1,46	—	—	—	0,50	1,89	1,89	1,89	1,89	1,89	1,89	—	—	—	0,55	2,21	2,21	2,21	2,21	2,21	2,21	—	—	—	0,60	2,53	2,53	2,53	2,53	2,53	2,53	—	—	—	0,63	2,73	2,73	2,73	2,73	2,73	2,73	—	—	—	0,75	3,50	3,50	3,50	3,50	3,50	3,50	—	—	—	0,88	3,68	3,68	3,68	3,68	3,68	3,68	—	—	—	1,00	3,84	3,84	3,84	3,84	3,84	3,84	—	—	—	u [mm]	40	3,0	3,0	3,0	3,0	3,0	3,0	—	—	—	50	4,5	4,5	4,5	4,5	4,5	4,5	—	—	—	60	6,0	6,0	6,0	6,0	6,0	6,0	—	—	—	70	7,4	7,4	7,4	7,4	7,4	7,4	—	—	—	80	8,8	8,8	8,8	8,8	8,8	8,8	—	—	—	90	10,1	10,1	10,1	10,1	10,1	10,1	—	—	—	≥ 100	11,5	11,5	11,5	11,5	11,5	11,5	—	—	—	$N_{R,k,II}$ [kN]		3,92	4,92	5,91	6,22	6,52	6,52	—	—	—	<p>No additional regulations.</p>
			t_{N1}, t_{N2}, d, D [mm]	t_{II} [mm]																																																																																																																																																																																																																																																																					
	4,00	5,00		6,00	7,00	8,00	$\geq 10,0$	—	—	—																																																																																																																																																																																																																																																															
$V_{R,k}$ [kN]	0,40	0,82	0,82	0,82	0,82	0,82	0,82	—	—	—																																																																																																																																																																																																																																																															
	0,50	0,93	1,12	1,30	1,30	1,30	1,30	—	—	—																																																																																																																																																																																																																																																															
	0,55	1,12	1,28	1,44	1,44	1,44	1,44	—	—	—																																																																																																																																																																																																																																																															
	0,60	1,31	1,45	1,58	1,58	1,58	1,58	—	—	—																																																																																																																																																																																																																																																															
	0,63	1,42	1,54	1,66	1,66	1,66	1,66	—	—	—																																																																																																																																																																																																																																																															
	0,75	1,88	1,94	2,00	2,00	2,00	2,00	—	—	—																																																																																																																																																																																																																																																															
	0,88	2,33	2,57	2,81	2,81	2,81	2,81	—	—	—																																																																																																																																																																																																																																																															
	1,00	2,74	3,15	3,56	3,56	3,56	3,56	—	—	—																																																																																																																																																																																																																																																															
$N_{R,k}$ [kN]	0,40	1,46	1,46	1,46	1,46	1,46	1,46	—	—	—																																																																																																																																																																																																																																																															
	0,50	1,89	1,89	1,89	1,89	1,89	1,89	—	—	—																																																																																																																																																																																																																																																															
	0,55	2,21	2,21	2,21	2,21	2,21	2,21	—	—	—																																																																																																																																																																																																																																																															
	0,60	2,53	2,53	2,53	2,53	2,53	2,53	—	—	—																																																																																																																																																																																																																																																															
	0,63	2,73	2,73	2,73	2,73	2,73	2,73	—	—	—																																																																																																																																																																																																																																																															
	0,75	3,50	3,50	3,50	3,50	3,50	3,50	—	—	—																																																																																																																																																																																																																																																															
	0,88	3,68	3,68	3,68	3,68	3,68	3,68	—	—	—																																																																																																																																																																																																																																																															
	1,00	3,84	3,84	3,84	3,84	3,84	3,84	—	—	—																																																																																																																																																																																																																																																															
u [mm]	40	3,0	3,0	3,0	3,0	3,0	3,0	—	—	—																																																																																																																																																																																																																																																															
	50	4,5	4,5	4,5	4,5	4,5	4,5	—	—	—																																																																																																																																																																																																																																																															
	60	6,0	6,0	6,0	6,0	6,0	6,0	—	—	—																																																																																																																																																																																																																																																															
	70	7,4	7,4	7,4	7,4	7,4	7,4	—	—	—																																																																																																																																																																																																																																																															
	80	8,8	8,8	8,8	8,8	8,8	8,8	—	—	—																																																																																																																																																																																																																																																															
	90	10,1	10,1	10,1	10,1	10,1	10,1	—	—	—																																																																																																																																																																																																																																																															
≥ 100	11,5	11,5	11,5	11,5	11,5	11,5	—	—	—																																																																																																																																																																																																																																																																
$N_{R,k,II}$ [kN]		3,92	4,92	5,91	6,22	6,52	6,52	—	—	—																																																																																																																																																																																																																																																															
<p>Self drilling screw</p>																																																																																																																																																																																																																																																																									
<p>Hilti S-CDH 65 GS 5,5 x L Hilti S-CDH 65 GSS 5,5 x L with hexagon head and sealing washer $\varnothing 19$ mm</p>	<p>Annex 21</p>																																																																																																																																																																																																																																																																								

Annex 11:
ETA-13/0179, Annex 22

Material:
 Fastener: stainless Steel (1.4301, 1.4401, 1.4571) - EN 10088
 Washer: stainless Steel (1.4301) - EN 10088
 Component I: S280GD, S320GD, S350GD - EN 10346
 Component II: S235, S275, S355 - EN 10025-1
 S280GD, S320GD, S350GD - EN 10346

Drilling capacity: $\Sigma t_i \leq 15,00$ mm

Timber substructures:
no performance determined

t_{N1}, t_{N2}, d, D [mm]	t_{II} [mm]									
	4,00	5,00	6,00	7,00	8,00	$\geq 10,0$	—	—	—	—
$V_{R,k}$ [kN]	0,40	0,82	0,82	0,82	0,82	0,82	0,82	—	—	—
	0,50	0,93	1,12	1,30	1,30	1,30	1,30	—	—	—
	0,55	1,12	1,28	1,44	1,44	1,44	1,44	—	—	—
	0,60	1,31	1,45	1,58	1,58	1,58	1,58	—	—	—
	0,63	1,42	1,54	1,66	1,66	1,66	1,66	—	—	—
	0,75	1,88	1,94	2,00	2,00	2,00	2,00	—	—	—
	0,88	2,33	2,57	2,81	2,81	2,81	2,81	—	—	—
	1,00	2,74	3,15	3,56	3,56	3,56	3,56	—	—	—
$N_{R,k}$ [kN]	0,40	1,65	1,65	1,65	1,65	1,65	1,65	—	—	—
	0,50	1,77	1,77	1,77	1,77	1,77	1,77	—	—	—
	0,55	2,26	2,26	2,26	2,26	2,26	2,26	—	—	—
	0,60	2,74	2,74	2,74	2,74	2,74	2,74	—	—	—
	0,63	3,03	3,03	3,03	3,03	3,03	3,03	—	—	—
	0,75	3,92	4,20	4,20	4,20	4,20	4,20	—	—	—
	0,88	3,92	4,32	4,32	4,32	4,32	4,32	—	—	—
	1,00	3,92	4,44	4,44	4,44	4,44	4,44	—	—	—
u [mm]	40	3,0	3,0	3,0	3,0	3,0	3,0	—	—	—
	50	4,5	4,5	4,5	4,5	4,5	4,5	—	—	—
	60	6,0	6,0	6,0	6,0	6,0	6,0	—	—	—
	70	7,4	7,4	7,4	7,4	7,4	7,4	—	—	—
	80	8,8	8,8	8,8	8,8	8,8	8,8	—	—	—
	90	10,1	10,1	10,1	10,1	10,1	10,1	—	—	—
≥ 100	11,5	11,5	11,5	11,5	11,5	11,5	—	—	—	
$N_{R,k,II}$ [kN]	3,92	4,92	5,91	6,22	6,52	6,52	—	—	—	

No additional regulations.

Self drilling screw	Annex 22
Hilti S-CDH 75 GS 5,5 x L Hilti S-CDH 75 GSS 5,5 x L with hexagon head and sealing washer Ø22 mm	

Annex 12:
ETA-13/0179, Annex 23

	<p>Material: Fastener: stainless Steel (1.4301, 1.4401, 1.4571) - EN 10088 Washer: stainless Steel (1.4301) - EN 10088 Component I: S280GD, S320GD, S350GD - EN 10346 Component II: S235, S275, S355 - EN 10025-1 S280GD, S320GD, S350GD - EN 10346</p>																																																																																																																																																																																																																																																																																																
<p>Drilling capacity: $\Sigma t_i \leq 15,00$ mm</p>																																																																																																																																																																																																																																																																																																	
<p>Timber substructures: no performance determined</p>																																																																																																																																																																																																																																																																																																	
<table border="1"> <thead> <tr> <th rowspan="2">t_{N1}, t_{N2}, d, D [mm]</th> <th colspan="10">t_{II} [mm]</th> </tr> <tr> <th>4,00</th> <th>5,00</th> <th>6,00</th> <th>7,00</th> <th>8,00</th> <th>$\geq 10,0$</th> <th>—</th> <th>—</th> <th>—</th> <th>—</th> </tr> </thead> <tbody> <tr> <td rowspan="8">$V_{R,k}$ [kN]</td> <td>0,40</td><td>0,82</td><td>0,82</td><td>0,82</td><td>0,82</td><td>0,82</td><td>0,82</td><td>—</td><td>—</td><td>—</td><td>—</td> </tr> <tr> <td>0,50</td><td>0,93</td><td>0,93</td><td>0,93</td><td>0,93</td><td>0,93</td><td>0,93</td><td>—</td><td>—</td><td>—</td><td>—</td> </tr> <tr> <td>0,55</td><td>1,12</td><td>1,12</td><td>1,12</td><td>1,12</td><td>1,12</td><td>1,12</td><td>—</td><td>—</td><td>—</td><td>—</td> </tr> <tr> <td>0,60</td><td>1,31</td><td>1,31</td><td>1,31</td><td>1,31</td><td>1,31</td><td>1,31</td><td>—</td><td>—</td><td>—</td><td>—</td> </tr> <tr> <td>0,63</td><td>1,42</td><td>1,42</td><td>1,42</td><td>1,42</td><td>1,42</td><td>1,42</td><td>—</td><td>—</td><td>—</td><td>—</td> </tr> <tr> <td>0,75</td><td>1,88</td><td>1,88</td><td>1,88</td><td>1,88</td><td>1,88</td><td>1,88</td><td>—</td><td>—</td><td>—</td><td>—</td> </tr> <tr> <td>0,88</td><td>2,33</td><td>2,33</td><td>2,33</td><td>2,33</td><td>2,33</td><td>2,33</td><td>—</td><td>—</td><td>—</td><td>—</td> </tr> <tr> <td>1,00</td><td>2,74</td><td>2,74</td><td>2,74</td><td>2,74</td><td>2,74</td><td>2,74</td><td>—</td><td>—</td><td>—</td><td>—</td> </tr> <tr> <td rowspan="8">$N_{R,k}$ [kN]</td> <td>0,40</td><td>1,46</td><td>1,46</td><td>1,46</td><td>1,46</td><td>1,46</td><td>1,46</td><td>—</td><td>—</td><td>—</td><td>—</td> </tr> <tr> <td>0,50</td><td>1,89</td><td>1,89</td><td>1,89</td><td>1,89</td><td>1,89</td><td>1,89</td><td>—</td><td>—</td><td>—</td><td>—</td> </tr> <tr> <td>0,55</td><td>2,21</td><td>2,21</td><td>2,21</td><td>2,21</td><td>2,21</td><td>2,21</td><td>—</td><td>—</td><td>—</td><td>—</td> </tr> <tr> <td>0,60</td><td>2,53</td><td>2,53</td><td>2,53</td><td>2,53</td><td>2,53</td><td>2,53</td><td>—</td><td>—</td><td>—</td><td>—</td> </tr> <tr> <td>0,63</td><td>2,73</td><td>2,73</td><td>2,73</td><td>2,73</td><td>2,73</td><td>2,73</td><td>—</td><td>—</td><td>—</td><td>—</td> </tr> <tr> <td>0,75</td><td>3,50</td><td>3,50</td><td>3,50</td><td>3,50</td><td>3,50</td><td>3,50</td><td>—</td><td>—</td><td>—</td><td>—</td> </tr> <tr> <td>0,88</td><td>3,68</td><td>3,68</td><td>3,68</td><td>3,68</td><td>3,68</td><td>3,68</td><td>—</td><td>—</td><td>—</td><td>—</td> </tr> <tr> <td>1,00</td><td>3,84</td><td>3,84</td><td>3,84</td><td>3,84</td><td>3,84</td><td>3,84</td><td>—</td><td>—</td><td>—</td><td>—</td> </tr> <tr> <td rowspan="6">u [mm]</td> <td>40</td><td>3,0</td><td>3,0</td><td>3,0</td><td>3,0</td><td>3,0</td><td>3,0</td><td>—</td><td>—</td><td>—</td><td>—</td> </tr> <tr> <td>50</td><td>4,5</td><td>4,5</td><td>4,5</td><td>4,5</td><td>4,5</td><td>4,5</td><td>—</td><td>—</td><td>—</td><td>—</td> </tr> <tr> <td>60</td><td>6,0</td><td>6,0</td><td>6,0</td><td>6,0</td><td>6,0</td><td>6,0</td><td>—</td><td>—</td><td>—</td><td>—</td> </tr> <tr> <td>70</td><td>7,4</td><td>7,4</td><td>7,4</td><td>7,4</td><td>7,4</td><td>7,4</td><td>—</td><td>—</td><td>—</td><td>—</td> </tr> <tr> <td>80</td><td>8,8</td><td>8,8</td><td>8,8</td><td>8,8</td><td>8,8</td><td>8,8</td><td>—</td><td>—</td><td>—</td><td>—</td> </tr> <tr> <td>90</td><td>10,1</td><td>10,1</td><td>10,1</td><td>10,1</td><td>10,1</td><td>10,1</td><td>—</td><td>—</td><td>—</td><td>—</td> </tr> <tr> <td>≥ 100</td><td>11,5</td><td>11,5</td><td>11,5</td><td>11,5</td><td>11,5</td><td>11,5</td><td>—</td><td>—</td><td>—</td><td>—</td> </tr> <tr> <td>$N_{R,k,II}$ [kN]</td> <td>3,92</td><td>4,92</td><td>5,91</td><td>6,22</td><td>6,52</td><td>6,52</td><td>—</td><td>—</td><td>—</td><td>—</td> </tr> </tbody> </table>	t_{N1}, t_{N2}, d, D [mm]	t_{II} [mm]										4,00	5,00	6,00	7,00	8,00	$\geq 10,0$	—	—	—	—	$V_{R,k}$ [kN]	0,40	0,82	0,82	0,82	0,82	0,82	0,82	—	—	—	—	0,50	0,93	0,93	0,93	0,93	0,93	0,93	—	—	—	—	0,55	1,12	1,12	1,12	1,12	1,12	1,12	—	—	—	—	0,60	1,31	1,31	1,31	1,31	1,31	1,31	—	—	—	—	0,63	1,42	1,42	1,42	1,42	1,42	1,42	—	—	—	—	0,75	1,88	1,88	1,88	1,88	1,88	1,88	—	—	—	—	0,88	2,33	2,33	2,33	2,33	2,33	2,33	—	—	—	—	1,00	2,74	2,74	2,74	2,74	2,74	2,74	—	—	—	—	$N_{R,k}$ [kN]	0,40	1,46	1,46	1,46	1,46	1,46	1,46	—	—	—	—	0,50	1,89	1,89	1,89	1,89	1,89	1,89	—	—	—	—	0,55	2,21	2,21	2,21	2,21	2,21	2,21	—	—	—	—	0,60	2,53	2,53	2,53	2,53	2,53	2,53	—	—	—	—	0,63	2,73	2,73	2,73	2,73	2,73	2,73	—	—	—	—	0,75	3,50	3,50	3,50	3,50	3,50	3,50	—	—	—	—	0,88	3,68	3,68	3,68	3,68	3,68	3,68	—	—	—	—	1,00	3,84	3,84	3,84	3,84	3,84	3,84	—	—	—	—	u [mm]	40	3,0	3,0	3,0	3,0	3,0	3,0	—	—	—	—	50	4,5	4,5	4,5	4,5	4,5	4,5	—	—	—	—	60	6,0	6,0	6,0	6,0	6,0	6,0	—	—	—	—	70	7,4	7,4	7,4	7,4	7,4	7,4	—	—	—	—	80	8,8	8,8	8,8	8,8	8,8	8,8	—	—	—	—	90	10,1	10,1	10,1	10,1	10,1	10,1	—	—	—	—	≥ 100	11,5	11,5	11,5	11,5	11,5	11,5	—	—	—	—	$N_{R,k,II}$ [kN]	3,92	4,92	5,91	6,22	6,52	6,52	—	—	—	—	<p>No additional regulations.</p>
t_{N1}, t_{N2}, d, D [mm]		t_{II} [mm]																																																																																																																																																																																																																																																																																															
	4,00	5,00	6,00	7,00	8,00	$\geq 10,0$	—	—	—	—																																																																																																																																																																																																																																																																																							
$V_{R,k}$ [kN]	0,40	0,82	0,82	0,82	0,82	0,82	0,82	—	—	—	—																																																																																																																																																																																																																																																																																						
	0,50	0,93	0,93	0,93	0,93	0,93	0,93	—	—	—	—																																																																																																																																																																																																																																																																																						
	0,55	1,12	1,12	1,12	1,12	1,12	1,12	—	—	—	—																																																																																																																																																																																																																																																																																						
	0,60	1,31	1,31	1,31	1,31	1,31	1,31	—	—	—	—																																																																																																																																																																																																																																																																																						
	0,63	1,42	1,42	1,42	1,42	1,42	1,42	—	—	—	—																																																																																																																																																																																																																																																																																						
	0,75	1,88	1,88	1,88	1,88	1,88	1,88	—	—	—	—																																																																																																																																																																																																																																																																																						
	0,88	2,33	2,33	2,33	2,33	2,33	2,33	—	—	—	—																																																																																																																																																																																																																																																																																						
	1,00	2,74	2,74	2,74	2,74	2,74	2,74	—	—	—	—																																																																																																																																																																																																																																																																																						
$N_{R,k}$ [kN]	0,40	1,46	1,46	1,46	1,46	1,46	1,46	—	—	—	—																																																																																																																																																																																																																																																																																						
	0,50	1,89	1,89	1,89	1,89	1,89	1,89	—	—	—	—																																																																																																																																																																																																																																																																																						
	0,55	2,21	2,21	2,21	2,21	2,21	2,21	—	—	—	—																																																																																																																																																																																																																																																																																						
	0,60	2,53	2,53	2,53	2,53	2,53	2,53	—	—	—	—																																																																																																																																																																																																																																																																																						
	0,63	2,73	2,73	2,73	2,73	2,73	2,73	—	—	—	—																																																																																																																																																																																																																																																																																						
	0,75	3,50	3,50	3,50	3,50	3,50	3,50	—	—	—	—																																																																																																																																																																																																																																																																																						
	0,88	3,68	3,68	3,68	3,68	3,68	3,68	—	—	—	—																																																																																																																																																																																																																																																																																						
	1,00	3,84	3,84	3,84	3,84	3,84	3,84	—	—	—	—																																																																																																																																																																																																																																																																																						
u [mm]	40	3,0	3,0	3,0	3,0	3,0	3,0	—	—	—	—																																																																																																																																																																																																																																																																																						
	50	4,5	4,5	4,5	4,5	4,5	4,5	—	—	—	—																																																																																																																																																																																																																																																																																						
	60	6,0	6,0	6,0	6,0	6,0	6,0	—	—	—	—																																																																																																																																																																																																																																																																																						
	70	7,4	7,4	7,4	7,4	7,4	7,4	—	—	—	—																																																																																																																																																																																																																																																																																						
	80	8,8	8,8	8,8	8,8	8,8	8,8	—	—	—	—																																																																																																																																																																																																																																																																																						
	90	10,1	10,1	10,1	10,1	10,1	10,1	—	—	—	—																																																																																																																																																																																																																																																																																						
≥ 100	11,5	11,5	11,5	11,5	11,5	11,5	—	—	—	—																																																																																																																																																																																																																																																																																							
$N_{R,k,II}$ [kN]	3,92	4,92	5,91	6,22	6,52	6,52	—	—	—	—																																																																																																																																																																																																																																																																																							
<p style="text-align: center;">Self drilling screw</p> <hr/> <p style="text-align: center;">Hilti S-CD 55 GS 5,5 x L Hilti S-CD 55 GSS 5,5 x L with hexagon head and sealing washer $\varnothing 16$ mm</p> <div style="float: right; text-align: right;">Annex 23</div>																																																																																																																																																																																																																																																																																																	

Annex 13:
ETA-13/0179, Annex 24

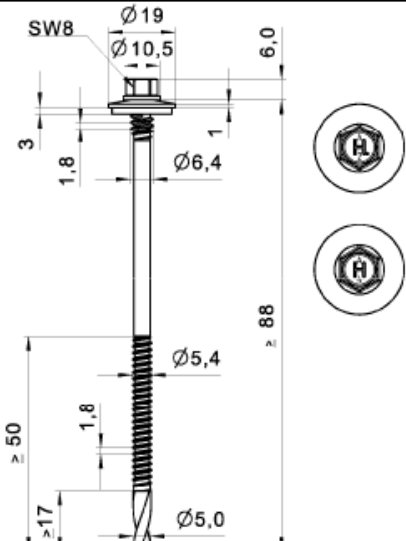

Material:
 Fastener: stainless Steel (1.4301, 1.4401, 1.4571) - EN 10088
 Washer: stainless Steel (1.4301) - EN 10088
 Component I: S280GD, S320GD, S350GD - EN 10346
 Component II: S235, S275, S355 - EN 10025-1
 S280GD, S320GD, S350GD - EN 10346

Drilling capacity: $\Sigma t_i \leq 15,00$ mm

Timber substructures:
no performance determined

t_{N1}, t_{N2}, d, D [mm]	t_{II} [mm]									
	4,00	5,00	6,00	7,00	8,00	$\geq 10,0$	—	—	—	—
$V_{R,k}$ [kN]	0,40	0,82	0,82	0,82	0,82	0,82	0,82	—	—	—
	0,50	0,93	1,12	1,30	1,30	1,30	1,30	—	—	—
	0,55	1,12	1,28	1,44	1,44	1,44	1,44	—	—	—
	0,60	1,31	1,45	1,58	1,58	1,58	1,58	—	—	—
	0,63	1,42	1,54	1,66	1,66	1,66	1,66	—	—	—
	0,75	1,88	1,94	2,00	2,00	2,00	2,00	—	—	—
	0,88	2,33	2,57	2,81	2,81	2,81	2,81	—	—	—
	1,00	2,74	3,15	3,56	3,56	3,56	3,56	—	—	—
$N_{R,k}$ [kN]	0,40	1,46	1,46	1,46	1,46	1,46	1,46	—	—	—
	0,50	1,89	1,89	1,89	1,89	1,89	1,89	—	—	—
	0,55	2,21	2,21	2,21	2,21	2,21	2,21	—	—	—
	0,60	2,53	2,53	2,53	2,53	2,53	2,53	—	—	—
	0,63	2,73	2,73	2,73	2,73	2,73	2,73	—	—	—
	0,75	3,50	3,50	3,50	3,50	3,50	3,50	—	—	—
	0,88	3,68	3,68	3,68	3,68	3,68	3,68	—	—	—
	1,00	3,84	3,84	3,84	3,84	3,84	3,84	—	—	—
u [mm]	40	3,0	3,0	3,0	3,0	3,0	3,0	—	—	—
	50	4,5	4,5	4,5	4,5	4,5	4,5	—	—	—
	60	6,0	6,0	6,0	6,0	6,0	6,0	—	—	—
	70	7,4	7,4	7,4	7,4	7,4	7,4	—	—	—
	80	8,8	8,8	8,8	8,8	8,8	8,8	—	—	—
	90	10,1	10,1	10,1	10,1	10,1	10,1	—	—	—
≥ 100	11,5	11,5	11,5	11,5	11,5	11,5	—	—	—	
$N_{R,k,II}$ [kN]	3,92	4,92	5,91	6,22	6,52	6,52	—	—	—	—

No additional regulations.

Self drilling screw

Hilti S-CD 65 GS 5,5 x L
 Hilti S-CD 65 GSS 5,5 x L
 with hexagon head and sealing washer $\varnothing 19$ mm

Annex 24

Annex 14:
ETA-13/0179, Annex 25

	<p>Material: Fastener: stainless Steel (1.4301, 1.4401, 1.4571) - EN 10088 Washer: stainless Steel (1.4301) - EN 10088 Component I: S280GD, S320GD, S350GD - EN 10346 Component II: S235, S275, S355 - EN 10025-1 S280GD, S320GD, S350GD - EN 10346</p>																																																																																																																																																																																																																																																																																																
<p>Drilling capacity: $\Sigma t_i \leq 15,00$ mm</p>																																																																																																																																																																																																																																																																																																	
<p>Timber substructures: no performance determined</p>																																																																																																																																																																																																																																																																																																	
<table border="1"> <thead> <tr> <th rowspan="2">t_{N1}, t_{N2}, d, D [mm]</th> <th colspan="10">t_{II} [mm]</th> </tr> <tr> <th>4,00</th> <th>5,00</th> <th>6,00</th> <th>7,00</th> <th>8,00</th> <th>$\geq 10,0$</th> <th>—</th> <th>—</th> <th>—</th> <th>—</th> </tr> </thead> <tbody> <tr> <td rowspan="8">$V_{R,k}$ [kN]</td> <td>0,40</td><td>0,82</td><td>0,82</td><td>0,82</td><td>0,82</td><td>0,82</td><td>0,82</td><td>—</td><td>—</td><td>—</td><td>—</td> </tr> <tr> <td>0,50</td><td>0,93</td><td>1,12</td><td>1,30</td><td>1,30</td><td>1,30</td><td>1,30</td><td>—</td><td>—</td><td>—</td><td>—</td> </tr> <tr> <td>0,55</td><td>1,12</td><td>1,28</td><td>1,44</td><td>1,44</td><td>1,44</td><td>1,44</td><td>—</td><td>—</td><td>—</td><td>—</td> </tr> <tr> <td>0,60</td><td>1,31</td><td>1,45</td><td>1,58</td><td>1,58</td><td>1,58</td><td>1,58</td><td>—</td><td>—</td><td>—</td><td>—</td> </tr> <tr> <td>0,63</td><td>1,42</td><td>1,54</td><td>1,66</td><td>1,66</td><td>1,66</td><td>1,66</td><td>—</td><td>—</td><td>—</td><td>—</td> </tr> <tr> <td>0,75</td><td>1,88</td><td>1,94</td><td>2,00</td><td>2,00</td><td>2,00</td><td>2,00</td><td>—</td><td>—</td><td>—</td><td>—</td> </tr> <tr> <td>0,88</td><td>2,33</td><td>2,57</td><td>2,81</td><td>2,81</td><td>2,81</td><td>2,81</td><td>—</td><td>—</td><td>—</td><td>—</td> </tr> <tr> <td>1,00</td><td>2,74</td><td>3,15</td><td>3,56</td><td>3,56</td><td>3,56</td><td>3,56</td><td>—</td><td>—</td><td>—</td><td>—</td> </tr> <tr> <td rowspan="8">$N_{R,k}$ [kN]</td> <td>0,40</td><td>1,65</td><td>1,65</td><td>1,65</td><td>1,65</td><td>1,65</td><td>1,65</td><td>—</td><td>—</td><td>—</td><td>—</td> </tr> <tr> <td>0,50</td><td>1,77</td><td>1,77</td><td>1,77</td><td>1,77</td><td>1,77</td><td>1,77</td><td>—</td><td>—</td><td>—</td><td>—</td> </tr> <tr> <td>0,55</td><td>2,26</td><td>2,26</td><td>2,26</td><td>2,26</td><td>2,26</td><td>2,26</td><td>—</td><td>—</td><td>—</td><td>—</td> </tr> <tr> <td>0,60</td><td>2,74</td><td>2,74</td><td>2,74</td><td>2,74</td><td>2,74</td><td>2,74</td><td>—</td><td>—</td><td>—</td><td>—</td> </tr> <tr> <td>0,63</td><td>3,03</td><td>3,03</td><td>3,03</td><td>3,03</td><td>3,03</td><td>3,03</td><td>—</td><td>—</td><td>—</td><td>—</td> </tr> <tr> <td>0,75</td><td>3,92</td><td>4,20</td><td>4,20</td><td>4,20</td><td>4,20</td><td>4,20</td><td>—</td><td>—</td><td>—</td><td>—</td> </tr> <tr> <td>0,88</td><td>3,92</td><td>4,32</td><td>4,32</td><td>4,32</td><td>4,32</td><td>4,32</td><td>—</td><td>—</td><td>—</td><td>—</td> </tr> <tr> <td>1,00</td><td>3,92</td><td>4,44</td><td>4,44</td><td>4,44</td><td>4,44</td><td>4,44</td><td>—</td><td>—</td><td>—</td><td>—</td> </tr> <tr> <td rowspan="7">u [mm]</td> <td>40</td><td>3,0</td><td>3,0</td><td>3,0</td><td>3,0</td><td>3,0</td><td>3,0</td><td>—</td><td>—</td><td>—</td><td>—</td> </tr> <tr> <td>50</td><td>4,5</td><td>4,5</td><td>4,5</td><td>4,5</td><td>4,5</td><td>4,5</td><td>—</td><td>—</td><td>—</td><td>—</td> </tr> <tr> <td>60</td><td>6,0</td><td>6,0</td><td>6,0</td><td>6,0</td><td>6,0</td><td>6,0</td><td>—</td><td>—</td><td>—</td><td>—</td> </tr> <tr> <td>70</td><td>7,4</td><td>7,4</td><td>7,4</td><td>7,4</td><td>7,4</td><td>7,4</td><td>—</td><td>—</td><td>—</td><td>—</td> </tr> <tr> <td>80</td><td>8,8</td><td>8,8</td><td>8,8</td><td>8,8</td><td>8,8</td><td>8,8</td><td>—</td><td>—</td><td>—</td><td>—</td> </tr> <tr> <td>90</td><td>10,1</td><td>10,1</td><td>10,1</td><td>10,1</td><td>10,1</td><td>10,1</td><td>—</td><td>—</td><td>—</td><td>—</td> </tr> <tr> <td>≥ 100</td><td>11,5</td><td>11,5</td><td>11,5</td><td>11,5</td><td>11,5</td><td>11,5</td><td>—</td><td>—</td><td>—</td><td>—</td> </tr> <tr> <td>$N_{R,k,II}$ [kN]</td> <td>3,92</td><td>4,92</td><td>5,91</td><td>6,22</td><td>6,52</td><td>6,52</td><td>—</td><td>—</td><td>—</td><td>—</td> </tr> </tbody> </table>	t_{N1}, t_{N2}, d, D [mm]	t_{II} [mm]										4,00	5,00	6,00	7,00	8,00	$\geq 10,0$	—	—	—	—	$V_{R,k}$ [kN]	0,40	0,82	0,82	0,82	0,82	0,82	0,82	—	—	—	—	0,50	0,93	1,12	1,30	1,30	1,30	1,30	—	—	—	—	0,55	1,12	1,28	1,44	1,44	1,44	1,44	—	—	—	—	0,60	1,31	1,45	1,58	1,58	1,58	1,58	—	—	—	—	0,63	1,42	1,54	1,66	1,66	1,66	1,66	—	—	—	—	0,75	1,88	1,94	2,00	2,00	2,00	2,00	—	—	—	—	0,88	2,33	2,57	2,81	2,81	2,81	2,81	—	—	—	—	1,00	2,74	3,15	3,56	3,56	3,56	3,56	—	—	—	—	$N_{R,k}$ [kN]	0,40	1,65	1,65	1,65	1,65	1,65	1,65	—	—	—	—	0,50	1,77	1,77	1,77	1,77	1,77	1,77	—	—	—	—	0,55	2,26	2,26	2,26	2,26	2,26	2,26	—	—	—	—	0,60	2,74	2,74	2,74	2,74	2,74	2,74	—	—	—	—	0,63	3,03	3,03	3,03	3,03	3,03	3,03	—	—	—	—	0,75	3,92	4,20	4,20	4,20	4,20	4,20	—	—	—	—	0,88	3,92	4,32	4,32	4,32	4,32	4,32	—	—	—	—	1,00	3,92	4,44	4,44	4,44	4,44	4,44	—	—	—	—	u [mm]	40	3,0	3,0	3,0	3,0	3,0	3,0	—	—	—	—	50	4,5	4,5	4,5	4,5	4,5	4,5	—	—	—	—	60	6,0	6,0	6,0	6,0	6,0	6,0	—	—	—	—	70	7,4	7,4	7,4	7,4	7,4	7,4	—	—	—	—	80	8,8	8,8	8,8	8,8	8,8	8,8	—	—	—	—	90	10,1	10,1	10,1	10,1	10,1	10,1	—	—	—	—	≥ 100	11,5	11,5	11,5	11,5	11,5	11,5	—	—	—	—	$N_{R,k,II}$ [kN]	3,92	4,92	5,91	6,22	6,52	6,52	—	—	—	—	<p>No additional regulations.</p>
t_{N1}, t_{N2}, d, D [mm]		t_{II} [mm]																																																																																																																																																																																																																																																																																															
	4,00	5,00	6,00	7,00	8,00	$\geq 10,0$	—	—	—	—																																																																																																																																																																																																																																																																																							
$V_{R,k}$ [kN]	0,40	0,82	0,82	0,82	0,82	0,82	0,82	—	—	—	—																																																																																																																																																																																																																																																																																						
	0,50	0,93	1,12	1,30	1,30	1,30	1,30	—	—	—	—																																																																																																																																																																																																																																																																																						
	0,55	1,12	1,28	1,44	1,44	1,44	1,44	—	—	—	—																																																																																																																																																																																																																																																																																						
	0,60	1,31	1,45	1,58	1,58	1,58	1,58	—	—	—	—																																																																																																																																																																																																																																																																																						
	0,63	1,42	1,54	1,66	1,66	1,66	1,66	—	—	—	—																																																																																																																																																																																																																																																																																						
	0,75	1,88	1,94	2,00	2,00	2,00	2,00	—	—	—	—																																																																																																																																																																																																																																																																																						
	0,88	2,33	2,57	2,81	2,81	2,81	2,81	—	—	—	—																																																																																																																																																																																																																																																																																						
	1,00	2,74	3,15	3,56	3,56	3,56	3,56	—	—	—	—																																																																																																																																																																																																																																																																																						
$N_{R,k}$ [kN]	0,40	1,65	1,65	1,65	1,65	1,65	1,65	—	—	—	—																																																																																																																																																																																																																																																																																						
	0,50	1,77	1,77	1,77	1,77	1,77	1,77	—	—	—	—																																																																																																																																																																																																																																																																																						
	0,55	2,26	2,26	2,26	2,26	2,26	2,26	—	—	—	—																																																																																																																																																																																																																																																																																						
	0,60	2,74	2,74	2,74	2,74	2,74	2,74	—	—	—	—																																																																																																																																																																																																																																																																																						
	0,63	3,03	3,03	3,03	3,03	3,03	3,03	—	—	—	—																																																																																																																																																																																																																																																																																						
	0,75	3,92	4,20	4,20	4,20	4,20	4,20	—	—	—	—																																																																																																																																																																																																																																																																																						
	0,88	3,92	4,32	4,32	4,32	4,32	4,32	—	—	—	—																																																																																																																																																																																																																																																																																						
	1,00	3,92	4,44	4,44	4,44	4,44	4,44	—	—	—	—																																																																																																																																																																																																																																																																																						
u [mm]	40	3,0	3,0	3,0	3,0	3,0	3,0	—	—	—	—																																																																																																																																																																																																																																																																																						
	50	4,5	4,5	4,5	4,5	4,5	4,5	—	—	—	—																																																																																																																																																																																																																																																																																						
	60	6,0	6,0	6,0	6,0	6,0	6,0	—	—	—	—																																																																																																																																																																																																																																																																																						
	70	7,4	7,4	7,4	7,4	7,4	7,4	—	—	—	—																																																																																																																																																																																																																																																																																						
	80	8,8	8,8	8,8	8,8	8,8	8,8	—	—	—	—																																																																																																																																																																																																																																																																																						
	90	10,1	10,1	10,1	10,1	10,1	10,1	—	—	—	—																																																																																																																																																																																																																																																																																						
	≥ 100	11,5	11,5	11,5	11,5	11,5	11,5	—	—	—	—																																																																																																																																																																																																																																																																																						
$N_{R,k,II}$ [kN]	3,92	4,92	5,91	6,22	6,52	6,52	—	—	—	—																																																																																																																																																																																																																																																																																							
<p style="text-align: center;">Self drilling screw</p> <hr/> <p style="text-align: center;">Hilti S-CD 75 GS 5,5 x L Hilti S-CD 75 GSS 5,5 x L with hexagon head and sealing washer $\varnothing 22$ mm</p> <div style="float: right; text-align: right;">Annex 25</div>																																																																																																																																																																																																																																																																																																	

Annex 15:
ETA-13/0179, Annex 26

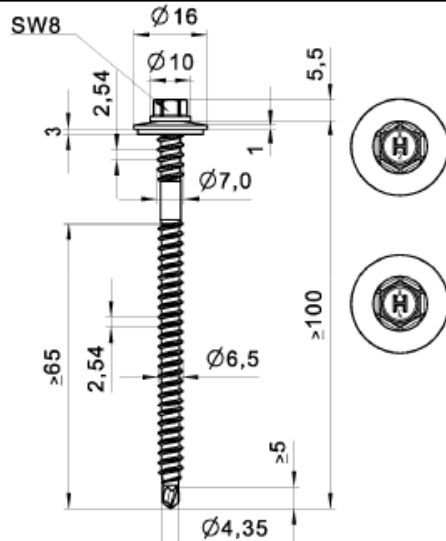

Material:
 Fastener: stainless Steel (1.4301, 1.4401, 1.4571) - EN 10088
 Washer: stainless Steel (1.4301) - EN 10088
 Component I: S280GD, S320GD - EN 10346
 Component II: Structural timber - EN 14081

Drilling capacity: $\Sigma t_i \leq 2,00$ mm

Timber substructures:
 performance determined with

$M_{y,Rk} = 9,741$ Nm
 $f_{ax,k} = 10,769$ N/mm² for $l_{ef} \geq 50,0$ mm

	t_{N1}, t_{N2} [mm]	d, D [mm]								
		30	40	50	60	70	80	100	120	≥ 140
$V_{R,I,k}$ [kN]	0,40	0,62	0,62	0,62	0,62	0,62	0,62	0,62	0,62	0,62
	0,50	0,98	0,98	0,98	0,98	0,98	0,98	0,98	0,98	0,98
	0,55	1,15	1,15	1,15	1,15	1,15	1,15	1,15	1,15	1,15
	0,60	1,37	1,37	1,37	1,37	1,37	1,37	1,37	1,37	1,37
	0,63	1,50	1,50	1,50	1,50	1,50	1,50	1,50	1,50	1,50
	0,75	2,17	2,17	2,17	2,17	2,17	2,17	2,17	2,17	2,17
	0,88	2,17	2,17	2,17	2,17	2,17	2,17	2,17	2,17	2,17
	1,00	2,17	2,17	2,17	2,17	2,17	2,17	2,17	2,17	2,17
$N_{R,I,k}$ [kN]	0,40	—	—	—	—	—	—	—	—	—
	0,50	1,72	1,72	1,72	1,72	1,72	1,72	1,72	1,72	1,72
	0,55	1,96	1,96	1,96	1,96	1,96	1,96	1,96	1,96	1,96
	0,60	2,12	2,12	2,12	2,12	2,12	2,12	2,12	2,12	2,12
	0,63	2,21	2,21	2,21	2,21	2,21	2,21	2,21	2,21	2,21
	0,75	2,73	2,73	2,73	2,73	2,73	2,73	2,73	2,73	2,73
	0,88	3,32	3,32	3,32	3,32	3,32	3,32	3,32	3,32	3,32
	1,00	3,50	3,50	3,50	3,50	3,50	3,50	3,50	3,50	3,50
u [mm]	—	5,0	7,0	9,0	11,0	13,0	18,0	18,0	18,0	
$N_{R,k,II}$ [kN]	—	3,15	3,15	3,15	3,15	3,15	3,15	3,15	3,15	

If component t_{N1} resp. t_{N2} is made of S320GD the grey highlighted values may be increased by 8,3%.
 The values listed above in dependence on the screw-in length l_{ef} and the values $N_{R,k,II}$ are valid for $k_{mod} = 0,90$ and timber strength grade C24 ($\rho_a = 350$ kg/m³). For other combinations of k_{mod} and timber strength grades see Annex 3.

Self drilling screw	Annex 26
Hilti S-CDW 51 S 6,5 x L Hilti S-CDW 51 SS 6,5 x L with hexagon head and sealing washer Ø16 mm	

Annex 16:
ETA-13/0179, Annex 27

	<p>Material: Fastener: stainless Steel (1.4301, 1.4401, 1.4571) - EN 10088 Washer: stainless Steel (1.4301) - EN 10088 Component I: S280GD, S320GD - EN 10346 Component II: Structural timber - EN 14081</p>																																																																																																																																																																																																																	
	<p>Drilling capacity: $\Sigma t_i \leq 2,00$ mm</p>																																																																																																																																																																																																																	
	<p>Timber substructures: performance determined with $M_{y,Rk} = 9,741$ Nm $f_{ax,k} = 10,769$ N/mm² for $l_{ef} \geq 50,0$ mm</p>																																																																																																																																																																																																																	
<table border="1"> <thead> <tr> <th rowspan="2">t_{N1}, t_{N2} [mm]</th> <th colspan="9">d, D [mm]</th> </tr> <tr> <th>30</th> <th>40</th> <th>50</th> <th>60</th> <th>70</th> <th>80</th> <th>100</th> <th>120</th> <th>≥ 140</th> </tr> </thead> <tbody> <tr> <td rowspan="8">$V_{R,I,k}$ [kN]</td> <td>0,40</td><td>0,62</td><td>0,62</td><td>0,62</td><td>0,62</td><td>0,62</td><td>0,62</td><td>0,62</td><td>0,62</td><td>0,62</td> </tr> <tr> <td>0,50</td><td>0,98</td><td>0,98</td><td>0,98</td><td>0,98</td><td>0,98</td><td>0,98</td><td>0,98</td><td>0,98</td><td>0,98</td> </tr> <tr> <td>0,55</td><td>1,15</td><td>1,15</td><td>1,15</td><td>1,15</td><td>1,15</td><td>1,15</td><td>1,15</td><td>1,15</td><td>1,15</td> </tr> <tr> <td>0,60</td><td>1,37</td><td>1,37</td><td>1,37</td><td>1,37</td><td>1,37</td><td>1,37</td><td>1,37</td><td>1,37</td><td>1,37</td> </tr> <tr> <td>0,63</td><td>1,50</td><td>1,50</td><td>1,50</td><td>1,50</td><td>1,50</td><td>1,50</td><td>1,50</td><td>1,50</td><td>1,50</td> </tr> <tr> <td>0,75</td><td>2,17</td><td>2,17</td><td>2,17</td><td>2,17</td><td>2,17</td><td>2,17</td><td>2,17</td><td>2,17</td><td>2,17</td> </tr> <tr> <td>0,88</td><td>2,17</td><td>2,17</td><td>2,17</td><td>2,17</td><td>2,17</td><td>2,17</td><td>2,17</td><td>2,17</td><td>2,17</td> </tr> <tr> <td>1,00</td><td>2,17</td><td>2,17</td><td>2,17</td><td>2,17</td><td>2,17</td><td>2,17</td><td>2,17</td><td>2,17</td><td>2,17</td> </tr> <tr> <td rowspan="8">$N_{R,I,k}$ [kN]</td> <td>0,40</td><td>—</td><td>—</td><td>—</td><td>—</td><td>—</td><td>—</td><td>—</td><td>—</td><td>—</td> </tr> <tr> <td>0,50</td><td>2,60</td><td>2,60</td><td>2,60</td><td>2,60</td><td>2,60</td><td>2,60</td><td>2,60</td><td>2,60</td><td>2,60</td> </tr> <tr> <td>0,55</td><td>3,10</td><td>3,10</td><td>3,10</td><td>3,10</td><td>3,10</td><td>3,10</td><td>3,10</td><td>3,10</td><td>3,10</td> </tr> <tr> <td>0,60</td><td>3,35</td><td>3,35</td><td>3,35</td><td>3,35</td><td>3,35</td><td>3,35</td><td>3,35</td><td>3,35</td><td>3,35</td> </tr> <tr> <td>0,63</td><td>3,50</td><td>3,50</td><td>3,50</td><td>3,50</td><td>3,50</td><td>3,50</td><td>3,50</td><td>3,50</td><td>3,50</td> </tr> <tr> <td>0,75</td><td>3,50</td><td>3,50</td><td>3,50</td><td>3,50</td><td>3,50</td><td>3,50</td><td>3,50</td><td>3,50</td><td>3,50</td> </tr> <tr> <td>0,88</td><td>3,50</td><td>3,50</td><td>3,50</td><td>3,50</td><td>3,50</td><td>3,50</td><td>3,50</td><td>3,50</td><td>3,50</td> </tr> <tr> <td>1,00</td><td>3,50</td><td>3,50</td><td>3,50</td><td>3,50</td><td>3,50</td><td>3,50</td><td>3,50</td><td>3,50</td><td>3,50</td> </tr> <tr> <td>u [mm]</td> <td>—</td><td>5,0</td><td>7,0</td><td>9,0</td><td>11,0</td><td>13,0</td><td>18,0</td><td>18,0</td><td>18,0</td> </tr> <tr> <td>$N_{R,k,II}$ [kN]</td> <td>3,15</td><td>3,15</td><td>3,15</td><td>3,15</td><td>3,15</td><td>3,15</td><td>3,15</td><td>3,15</td><td>3,15</td> </tr> </tbody> </table>										t_{N1}, t_{N2} [mm]	d, D [mm]									30	40	50	60	70	80	100	120	≥ 140	$V_{R,I,k}$ [kN]	0,40	0,62	0,62	0,62	0,62	0,62	0,62	0,62	0,62	0,62	0,50	0,98	0,98	0,98	0,98	0,98	0,98	0,98	0,98	0,98	0,55	1,15	1,15	1,15	1,15	1,15	1,15	1,15	1,15	1,15	0,60	1,37	1,37	1,37	1,37	1,37	1,37	1,37	1,37	1,37	0,63	1,50	1,50	1,50	1,50	1,50	1,50	1,50	1,50	1,50	0,75	2,17	2,17	2,17	2,17	2,17	2,17	2,17	2,17	2,17	0,88	2,17	2,17	2,17	2,17	2,17	2,17	2,17	2,17	2,17	1,00	2,17	2,17	2,17	2,17	2,17	2,17	2,17	2,17	2,17	$N_{R,I,k}$ [kN]	0,40	—	—	—	—	—	—	—	—	—	0,50	2,60	2,60	2,60	2,60	2,60	2,60	2,60	2,60	2,60	0,55	3,10	3,10	3,10	3,10	3,10	3,10	3,10	3,10	3,10	0,60	3,35	3,35	3,35	3,35	3,35	3,35	3,35	3,35	3,35	0,63	3,50	3,50	3,50	3,50	3,50	3,50	3,50	3,50	3,50	0,75	3,50	3,50	3,50	3,50	3,50	3,50	3,50	3,50	3,50	0,88	3,50	3,50	3,50	3,50	3,50	3,50	3,50	3,50	3,50	1,00	3,50	3,50	3,50	3,50	3,50	3,50	3,50	3,50	3,50	u [mm]	—	5,0	7,0	9,0	11,0	13,0	18,0	18,0	18,0	$N_{R,k,II}$ [kN]	3,15	3,15	3,15	3,15	3,15	3,15	3,15	3,15	3,15
t_{N1}, t_{N2} [mm]	d, D [mm]																																																																																																																																																																																																																	
	30	40	50	60	70	80	100	120	≥ 140																																																																																																																																																																																																									
$V_{R,I,k}$ [kN]	0,40	0,62	0,62	0,62	0,62	0,62	0,62	0,62	0,62	0,62																																																																																																																																																																																																								
	0,50	0,98	0,98	0,98	0,98	0,98	0,98	0,98	0,98	0,98																																																																																																																																																																																																								
	0,55	1,15	1,15	1,15	1,15	1,15	1,15	1,15	1,15	1,15																																																																																																																																																																																																								
	0,60	1,37	1,37	1,37	1,37	1,37	1,37	1,37	1,37	1,37																																																																																																																																																																																																								
	0,63	1,50	1,50	1,50	1,50	1,50	1,50	1,50	1,50	1,50																																																																																																																																																																																																								
	0,75	2,17	2,17	2,17	2,17	2,17	2,17	2,17	2,17	2,17																																																																																																																																																																																																								
	0,88	2,17	2,17	2,17	2,17	2,17	2,17	2,17	2,17	2,17																																																																																																																																																																																																								
	1,00	2,17	2,17	2,17	2,17	2,17	2,17	2,17	2,17	2,17																																																																																																																																																																																																								
$N_{R,I,k}$ [kN]	0,40	—	—	—	—	—	—	—	—	—																																																																																																																																																																																																								
	0,50	2,60	2,60	2,60	2,60	2,60	2,60	2,60	2,60	2,60																																																																																																																																																																																																								
	0,55	3,10	3,10	3,10	3,10	3,10	3,10	3,10	3,10	3,10																																																																																																																																																																																																								
	0,60	3,35	3,35	3,35	3,35	3,35	3,35	3,35	3,35	3,35																																																																																																																																																																																																								
	0,63	3,50	3,50	3,50	3,50	3,50	3,50	3,50	3,50	3,50																																																																																																																																																																																																								
	0,75	3,50	3,50	3,50	3,50	3,50	3,50	3,50	3,50	3,50																																																																																																																																																																																																								
	0,88	3,50	3,50	3,50	3,50	3,50	3,50	3,50	3,50	3,50																																																																																																																																																																																																								
	1,00	3,50	3,50	3,50	3,50	3,50	3,50	3,50	3,50	3,50																																																																																																																																																																																																								
u [mm]	—	5,0	7,0	9,0	11,0	13,0	18,0	18,0	18,0																																																																																																																																																																																																									
$N_{R,k,II}$ [kN]	3,15	3,15	3,15	3,15	3,15	3,15	3,15	3,15	3,15																																																																																																																																																																																																									
<p>If component t_{N1} resp. t_{N2} is made of S320GD the grey highlighted values may be increased by 8,3%. The values listed above in dependence on the screw-in length l_{ef} and the values $N_{R,k,II}$ are valid for $k_{mod} = 0,90$ and timber strength grade C24 ($\rho_a = 350$ kg/m³). For other combinations of k_{mod} and timber strength grades see Annex 3.</p>																																																																																																																																																																																																																		
<p>Self drilling screw</p>																																																																																																																																																																																																																		
<p>Hilti S-CDW 61 S 6,5 x L Hilti S-CDW 61 SS 6,5 x L Hilti S-CDW 71 S 6,5 x L Hilti S-CDW 71 SS 6,5 x L with hexagon head and sealing washer $\geq \text{Ø}19$ mm</p>								<p>Annex 27</p>																																																																																																																																																																																																										