

MFPI 3

$H_{min} = 140 \text{ mm}$
 $H_{max} = 1200 \text{ mm}$
 $F_{rec} = 20 \text{ kN}$

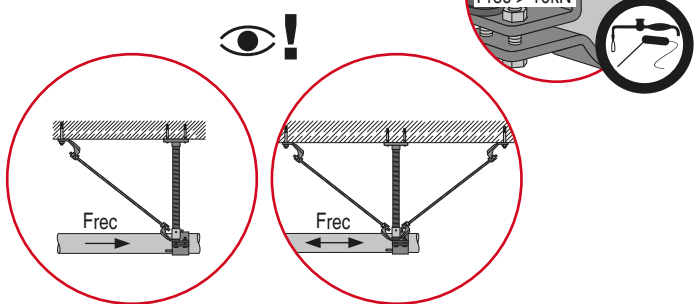
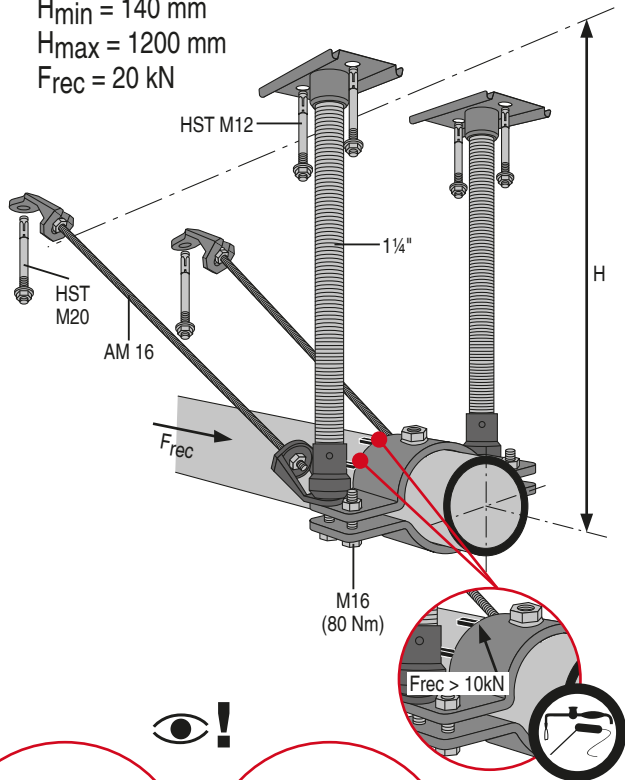

MFPI 3a

$H_{min} = 250 \text{ mm}$
 $H_{max} = 800 \text{ mm}$
 $F_{rec} [\text{kN}] = 960 \text{ Nm/H} [\text{mm}] \leq 6 \text{ kN}$

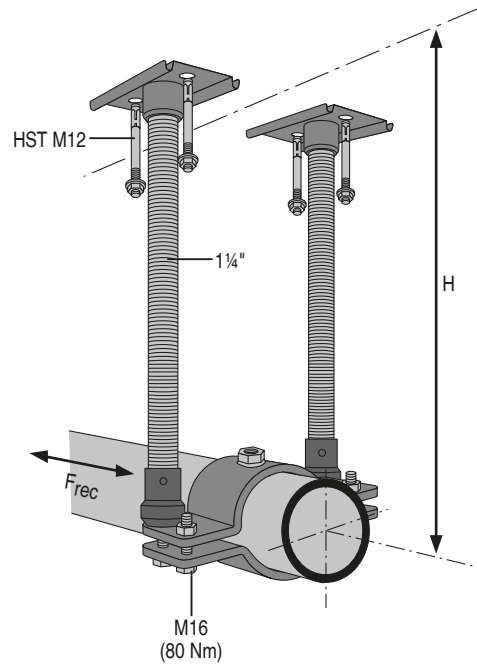

MFPI 3	MFPI 3a
MFP-NW ... 	
MFP-BPI 16 # 254459 	
MFP-API 3 # 254463 	
2x 1 1/4" # 248532 	
2x AM 16 # 216424 	
4x HST M12/20 # 371587 	
2x HST M20/30 # 371598 	
SW 19, SW 24, SW 30 	SW 19, SW 24

