

h_2	10 mm	28 mm	3 mm
d_o [mm]	35		
h_{nom} [mm]	35		

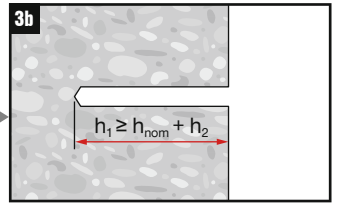

h_{nom}	35 mm
	18 Nm
SIW 4AT-22 1/2"	✓
SIW 6AT-A22 1/2"	✓
SIW 6-22 1/2"	✗

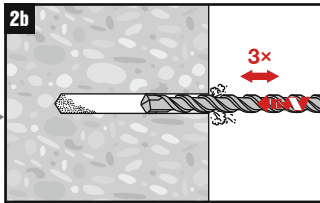
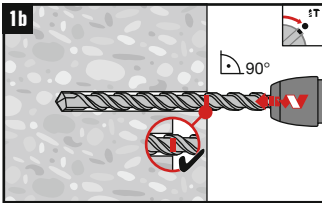
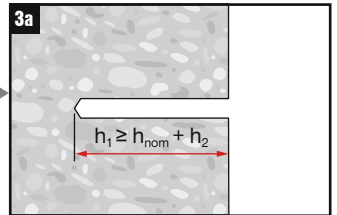
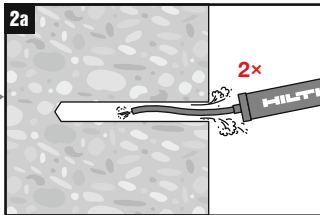
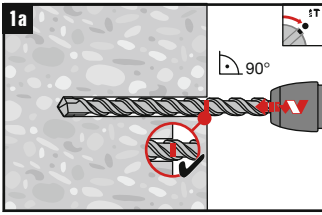
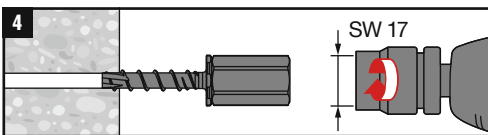
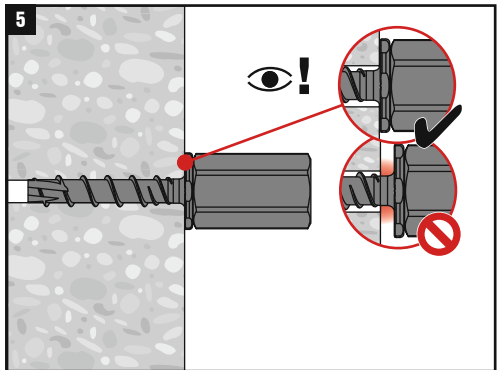
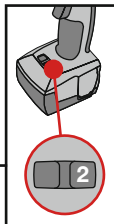

Min. 4.6 strength class, DIN 976-1
M8 / M10

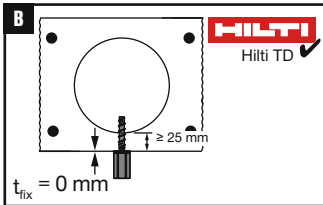
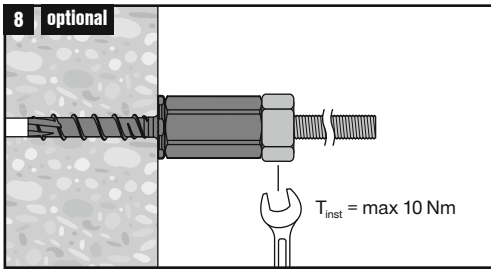
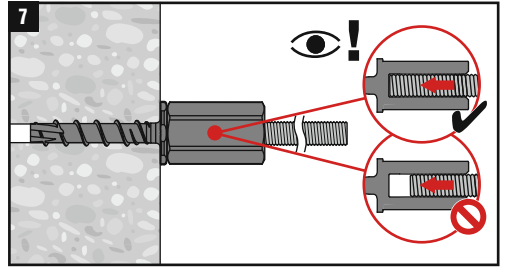
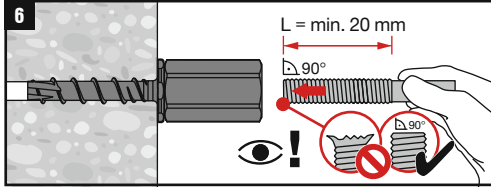

	SIW 4AT-22 1/2"	✓
	SIW 6AT-A22 1/2"	✓
	18 Nm	

